



Road Safety Products

Secure construction sites

General Catalogue

April 2010



WEMAS ABSPERRTECHNIK: ... safety assured!



Wherever there's an issue concerning safety, immaterial whether it's in Germany or across Europe, construction companies, road builders and other industries turn to products from WEMAS. Since 1971 WEMAS has specialised in the manufacture and distribution of products for professionally safeguarding working environments along roads.

WEMAS develops and manufactures innovative barrier equipment, construction site illumination, delineators, base plates, traffic cones and various accessories under one roof.

WEMAS is your Partner with excellent knowledge

- BAST-approved products
- all from one hand
- own, modern production
- use high quality raw material
- fast delivery
- service across Europe
- qualified Consultants
- education service

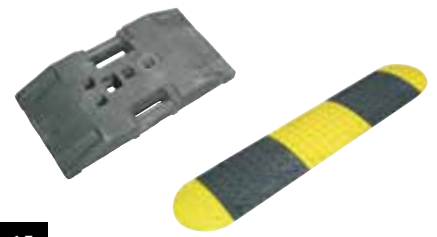

6-15

BASES



16-23

DELINEATORS



Head Office Gütersloh, Germany



24-35

BARRIER



Office Pulheim, Germany



36-41

WARNINGLIGHTS



42-55

TRAFFIC CONES



Office Radefeld, Germany



56-61

CYLINDER



62-78

ACCESSORIES

WEMAS Road Safety Products



**Quality and service are a matter of course at WEMAS.
On request we can also realise your own ideas in plastic.
So choose the right path - choose WEMAS!**



■ new safety barrier, page: 24

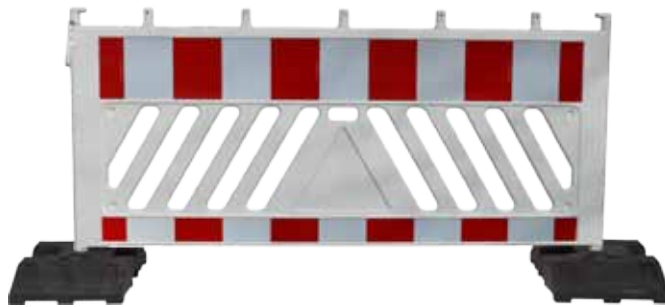

■ huge traffic cone range (incl. Molan traffic cones) page: 42



■ stackable barrels, page 56



WEMAS Base plates



- BAST-tested delineator systems according to TL Leitbaken 97
- Huge variety of base plates
- On request with your name or logo
- Especially stable and antislip



WEMAS base plate type MB TL 92

BAST tested

tested for delineators, certificate no: 99 2K 03(B,Z) / 99 2K 05 (B,Z) / 96 2K 02 / 02 2K 03 (B,Z) / 02 2K 15 (B,Z) standard with swivel adapter W03
 Battery box for battery 6V/120Ah included
 Dimensions: 800x400x100 mm.

301.001010.00.00	MB TL 92 base plate with swivel adapter Weight approx. 28 kg	(packaging unit 36 pieces)
301.001011.00.00	MB TL 92 base plate with swivel adapter and name stamping. Weight approx. 28 kg	(packaging unit 36 pieces)

Minimum quantity for base plates with name stamp: 5 pallets (1 pallet = 36 pieces).

- BAST tested
- 2 carrying handles
- especially stable and antislip
- shatter-proof, stackable
- resistant against to oil, frost, salt



hole for safety pin of delineator type S

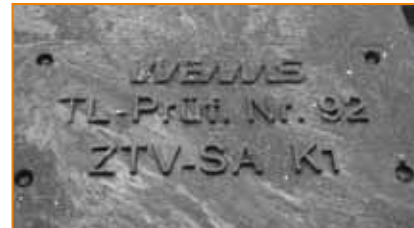
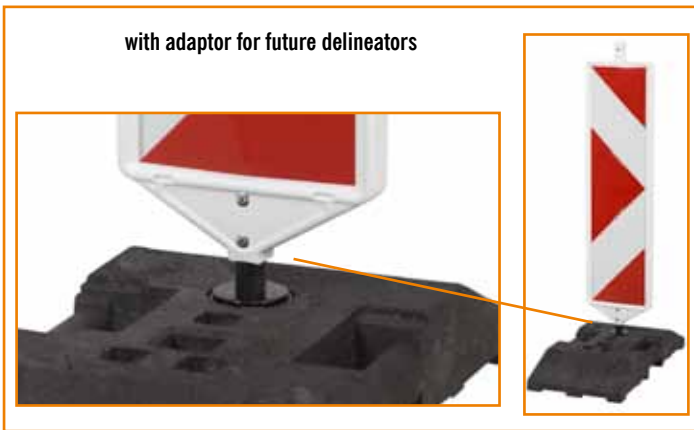

stamp TL-test

WEMAS base plate type TL 90/91

BAST tested

tested for delineators, certificate no: 94 2 K 012 (D,J,R,X,Y) / TL 1229 and 02 2K 07,08 (A) standard with swivel adapter W03. Battery box for battery 6V/120Ah included.
 Dimensions 860x450x100 mm.

301.002010.90.00	TL 90/91 base plate with swivel adapter Weight approx. 29 kg	
301.002020.91.00	TL 90/91 base plate with swivel adapter and name stamp Weight approx. 29 kg	
		packaging unit: 36 pieces

Minimum quantity for base plates with name stamp: 5 pallets (1 pallet = 36 pieces)

- BAST tested
- 2 carrying handles
- especially stable and antislip
- shatter-proof, stackable
- resistant against oil, frost, salt



Base plate type K1



Weight approx. 29 kg

Base plate K1 with support: 2 x 60x60 mm, 3 x 40x40 Ø42 mm.

301.001020.00.00	K1 base plate
301.001020.00.01	K1 base plate with name stamp

packaging unit: pallet = 36 pieces

Minimum quantity for base plates with name stamp: 5 pallets.

base plate TL erection aid type "K1-Koffer"

- tested -



Weight approx.. 36 kg

NEW



TL-sign stand type E (3 TL bases)
(see page 64)

**according to TL-Aufstellvorrichtung 97, for fixing of signs, barriers and safety barriers. Dimensions 860x450x100 mm.
support: 1 x 60x60 mm, 3 x 40x40 Ø42 mm.**

301.003010.00.00	type A erection aid (Koffer)
301.003011.00.00	type A erection aid (Koffer) with name stamp
308.057007.00.40	TL erection aid type E K1-K6 with support 40x40 mm only approx. 8 kg (see page 64)

packaging unit: pallet = 36 pieces

Minimum quantity for base plates with name stamp: 5 pallets.

base plate TL erection aid type "K2"

- tested -

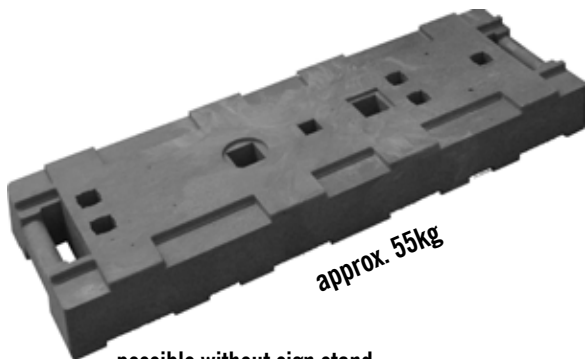

approx. 55kg

possible without sign stand.

**according to TL-Aufstellvorrichtung 97, for fixing of signs.
Also suitable for motorways because of the stability**

**Supports: 2 x 60x60 mm, 6 x 40x40 Ø42 mm.
Dimensions 1.200 x 400 x 120 mm (LxBxH).**

301.003020.00.00	type A erection aid K2. Weight > 50 kg
301.003021.00.00	type A erection aid K2 with name stamp. Weight > 50 kg

packaging unit: pallet = 18 pieces

Minimum quantity for base plates with name stamp: 5 pallets.

Dimensions and weights are approx. declared. Margin +/- 5 %. Subject to modifications and amendments.

Excerpt from the German regulation ZTV-SA 97

6.2 Aufstellen von Verkehrsschildern

6.2.1 Allgemeines

(1) Verkehrsschilder sind gut sichtbar, nicht spiegelnd, standsicher, verdrehsicher, senkrecht zur Straßenoberfläche im Verkehrsbereich und fest (wackelfrei) anzubringen.

(2) Gefahrzeichen (Dreiecke) sind immer über Vorschriftzeichen (Ronden) anzubringen.

6.2.2 Aufstellhöhe von Schildern

(1) Der Abstand zwischen Unterkante Verkehrsschild und Aufstellfläche beträgt in der Regel:































- 2,0 m außerhalb der Fahrbahn und über Gehwegen,
- 2,2 m über Radwegen.

6.2.4 Standsicherheit

(1) Bei Berechnung der Standsicherheit ist innerorts eine Windlast von 0,25 kN/m², außerorts von 0,42 kN/m² zugrunde zu legen.

Details see page 64

Übersichtstabelle für Aufstellung von Standardverkehrszeichen (Gr. 2) Inner- und Außerorts in Höhe 2,20 m

 Ronde Ø 600 mm	2 x  Oder 1 x 	2 x  Oder 1 x 	
 Dreieck SL 900 mm	2 x  Oder 1 x 	2 x  Oder 1 x 	
 2 Ronden Ø 600 mm	4 x  Oder 2 x  + 	4 x  Oder 2 x  +	
 Dreieck SL 900 mm mit Zusatzzeichen 3 zeilig	4 x  Oder 2 x  + 	4 x  Oder 3 x  +	
 Dreieck SL 900 mm und Ronde Ø 600 mm	4 x  Oder 2 x  + 	6 x  Oder 3 x  +	
Legende:	 = TL Aufstellvorrichtung "K1" 38,00 KG	 = TL Aufstellvorrichtung "K2" 55,00 KG	 = TL Schilderstander 28,00 KG

WEMAS base plate type „Universal“



base plate „Universal“ 800x400x100 (lxbxh) mm with support: 2 x 60x60 mm, 3 x 40x40 Ø 42 mm. Further supports i.e. with cross 40x80mm available. Name stamp on both sides possible. Weight approx. 25 kg.

301.001020.00.01	Base plate „Universal“ - with support: 2 x 60x60, 3 x 40x40 / Ø 42 mm
301.001021.00.01	Base plate „Universal“ - with name stamp (one site) - 2 x 60x60, 3 x 40x40 / Ø 42 mm
301.001061.00.00	Base plate „Universal“ with cross 1 x 60x60, 3 x 40x40 / Ø 42 mm, 1 x 40x80mm (cross)
301.001061.00.01	Base plate „Universal“ with cross - and name stamp 1 x 60x60, 3 x 40x40 / Ø 42 mm, 1 x 40x80mm (cross)
301.001022.00.00	Base plate „Universal“ NL 2 x 60x60, 2 x 40x40 / Ø 42 mm, 1 x Ø48mm
301.001022.00.01	Base plate „Universal“ NL- with name stamp 2 x 60x60, 2 x 40x40 / Ø 42 mm, 1 x Ø48mm

packaging unit: pallets = 36 pieces

Full truck = 900 pieces

Minimum quantity for base plates with name stamp: 5 pallets (180 pieces).



Also stackable with
K1 oder MB-TL



Base plate type R 450

Base plate round, stackable for fixing of pillars, bollards etc.
Diameter approx. 450 mm, height approx. 100 mm.

301.004010.40.40	R 450 support 40x40 / Ø 42 mm Weight approx. 15 kg (pic. 1)
301.004011.60.60	R 450 support 60x60 mm Weight approx. 15 kg (pic. 2)
301.004012.62.00	R 450 support 62 mm Ø Weight approx. 15 kg (pic. 3)
390.060001.00.00	Casing shoe for 40x40 / Ø42 mm for base plates with support 60x60 (pic. 4)
302.605000.00.11	Swivel adapter for base plates with support 60x60 (pic. 5)

packaging unit: palett = 60 pieces



Base plate type R 500

Base plate round, stackable for fixing of pillars, bollards etc.
Diameter approx. 500 mm, height approx. 140 mm.

301.004020.00.00	R 500 support 40x40, 60x60, Ø 42 mm (1) Weight approx. 26 kg
301.004021.00.00	R 500 with name stamp Weight approx. 26 kg
301.040210.00.00	R 500 Export (2) Weight approx. 26 kg
301.040211.00.00	R 500 Export with name stamp Weight approx. 26 kg

packaging unit: 36 pieces

Minimum quantity for base plates with name stamp: 5 pallets.



Base plate type R 400x400

301.001023.40.40	Base plate 400x400 mm, support 40x40 mm Weight 10 kg (pic. 1)
301.001023.60.60	Base plate 400x400 mm, support 60x60 mm Weight 10 kg (pic. 2)
301.001023.62.00	Base plate 400x400 mm, support Ø 62 mm Weight 10 kg

packaging unit: 60 pieces

Minimum quantity for base plates with name stamp: 5 pallets.



WEMAS base plate fillabel



WEMAS base plate from HDPE. Supports: 60x60 mm and 3 40x40 mm also available with swivel adapter (W03).

301.001099.00.00	Base plate from HDPE, fillable	(packaging unit 36 pieces)
------------------	--------------------------------	----------------------------

Minimum quantity for base plates with name stamp: 5 pallets (1 pallet = 36 pieces).

WEMAS base plate for site fences

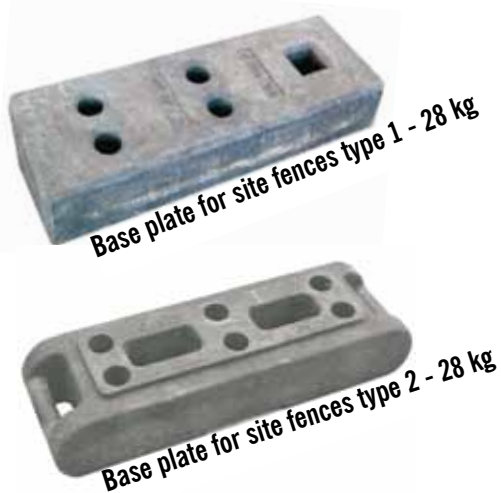

For fixing of site fences
Supports 42 mm .

301.001049.00.00	Bauzaunfuß type 1 (4xØ42mm, 1x60x60mm) Weight approx. 28 kg
301.001049.10.00	Bauzaunfuß type 1 with name stamp Weight approx. 28 kg
301.001042.00.00	Bauzaunfuß type 2 (6xØ42mm) Weight approx. 28 kg
301.001043.00.00	Bauzaunfuß type 2 with name stamp Weight approx. 28 kg
packaging unit: 50 pieces	

Minimum quantity for base plates with name stamp: 5 pallets (1 pallet = 50 pieces)

Dimensions and weights are approx. declared.
Margin + / - 5%.
Subject to modifications and amendments.



Base plate for site fences type 1 to carry with 2 hands



Base plate for site fences type 2 to carry with one hand because of 2 handles



WEMAS gurat rail

Guard rail from PVC with warning sign and reflectors/ painted. Total length 1000 mm, connection 250 mm + guard rail 750 mm

301.005012.00.00	Guard rail yellow 750/1000 mm Weight approx. 20 kg	
301.005022.00.00	Guard rail top piece yellow Weight approx. 15 kg	
301.005023.00.00	Guard rail end piece yellow Weight approx. 15 kg	
packaging unit: 40 pieces		

302.605102.00.01	Warning sign for guard rail, film class RA1	(packaging unit 40 pieces)
302.605102.00.02	Warning sign for guard rail, film class RA2-B	(packaging unit 40 pieces)
302.605000.00.02	Swivel adapter inner section with tube (pic. 1) for warning sign	packaging unit 100 pieces)
302.605000.00.01	Swivel adapter outer part for base plate (pic. 2)	(packaging unit 100 pieces)



Warning sign also with swivel adapter

WEMAS accessories for base plates

301.002100.00.00	Transport trolley for base plates (pic. 1)	
390.060001.00.00	Chasing shoe Universal for tube 40x40 mm (pic. 2) and Ø 42 mm	
390.060002.00.00	Chasing shoe for round tube Ø 42 mm (o. pic.)	
302.605000.00.01	Swivel adapter outer part (W03) for base plate (pic. 3)	
302.605000.00.11	Swivel adapter outer part for base plate (pic. 4)	
301.000002.00.00	Embossing plate for base plates	
301.000001.00.00	Embossing costs for base plates	
308.470001.02.00	Insert for base plates zinc coated for fixing safety barriers (pic. 5)	(packaging unit 10 pieces)
301.100000.00.00	Storage and transport rack for base plates zinc coated, stackable, for 36 WEMAS base plates	
packaging unit: Swivel adapter and chasing shoe: each 100 pieces transport trolley, storage and transport rack: each 1 piece		

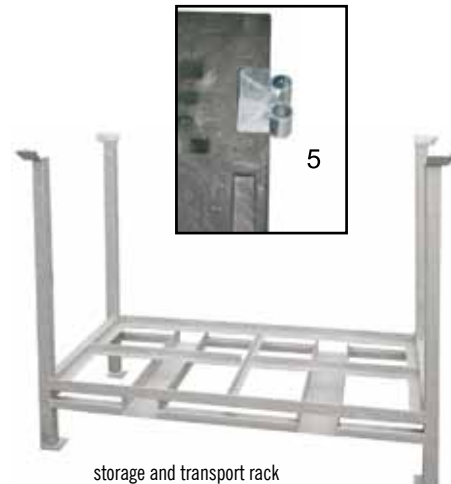

storage and transport rack

WEMAS hose and cable bridges, protection for hoses until 3"

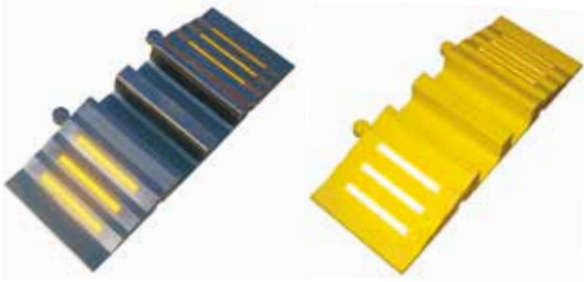

From PVC, with reflective film type 3 (Diamond Grade). Standard colour black, can be widened and used on both sides as required.

Weight: 12,50kg

Dimensions 300 x 850 x 90 mm

Feed-throughs 2 x 90 x 75 mm

390.070000.00.00 WEMAS hose and cable bridge
black

390.070000.00.10 WEMAS hose and cable bridge
yellow

packaging unit: 1 piece



hose and cable bridge



hose and cable bridge covered



test fire brigade

WEMAS cable bridge, protection for hoses and cables until max. diameter Ø 40 mm



From flexible elastomers, Standard colour yellow

Dimensions: 1500 x 210 x 65 mm

Weight: 15,00 kg

Feed-throughs: 1 x Ø 40 mm und 2 x Ø 20 mm

390.070000.15.10 WEMAS cable bridge 1500
yellow

packaging unit: 1 piece



Speed bumps

Manufactured from using material, black/yellow, self-connecting (pic.1). Complete with 2 reflectors on either side. Heights 30, 50 und 75 mm. Centre and end pieces using yellow imbued elastomers, thereby ensuring a permanent yellow finish. (see image cross-section).
Weight per meter approx. 13,5 kg (30mm), approx. 22 kg (50mm), approx. 34 kg (75mm).

WEMAS speed bumps 30 mm high

390.069110.00.00	Centre piece yellow 500x420x30 mm
390.069110.01.00	Centre piece black 500x420x30 mm
390.069210.00.00	Top piece yellow 250x420x30 mm (with connecting piece)
390.069210.01.00	End piece yellow 250x420x30 mm
390.069220.00.00	Top piece black 250x420x30 mm (with connecting piece)
390.069220.01.00	End piece black 250x420x30 mm

packaging unit: 1 piece

WEMAS Speed bumps 50 mm high

390.069111.00.00	Centre piece yellow 500x420x50 mm
390.069111.01.00	Centre piece black 500x420x50 mm
390.069211.00.00	Top piece yellow 250x420x50 mm (with connecting piece)
390.069211.01.00	End piece yellow 250x420x50 mm
390.069221.00.00	Top piece black 250x420x50 mm (with connecting piece)
390.069221.01.00	End piece black 250x420x50 mm

packaging unit : 1 piece

WEMAS Speed bumps 75 mm high

390.069112.00.00	Centre piece yellow 500x420x75 mm
390.069112.01.00	Centre piece black 500x420x75 mm
390.069212.00.00	Top piece yellow 250x420x75 mm (with connection piece)
390.069212.01.00	End piece yellow 250x420x75 mm
390.069222.00.00	Top piece black 250x420x75 mm (with connecting piece)
390.069222.01.00	End piece black 250x420x75 mm

packaging unit: 1 piece



Tempo Stop Ø 420 mm



Cross-section, yellow centre piece

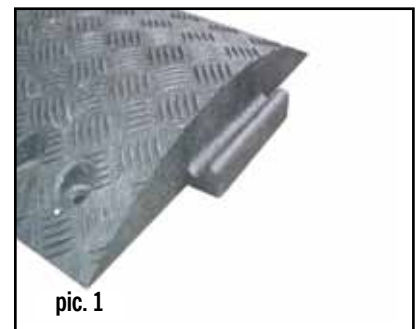

pic. 1

Recommended speed for speed bumps:

Height 30 mm	Recommended speed	max.: 30 km/h
Height 50 mm	Recommended speed	max.: 20 km/h
Height 75 mm	Recommended speed	max.: 10 km/h

WEMAS delineators

FUTURE UNIVERSAL SWIVEL ADAPTER

- Especially economic through the replacing swivel adapter
- Assured easy handling
- Long live term through high quality materials
- Usable with base plates from different producer (TL30/31/33, TL50-56)
- Also available with reflective films
- BAST-tested according to TL Leitbaken 97
- registered design
- with standard or arrow film



Approved in following combinations:



type: MB TL 92

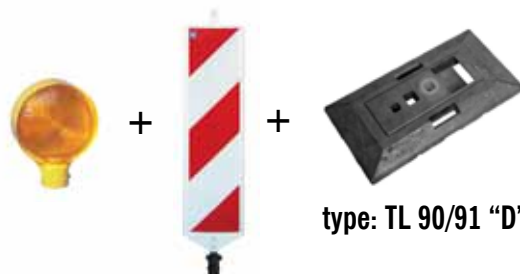

type: TL 90/91 "D"



standard
direction left
direction right



arrow
direction left
direction right

WEMAS delineators

Reflective films	Film classes RA1 and RA2-B, RA3 on request
Film colours and film classes	Standard- and arrow film red/white (red/yellow also available)
Delineator colours	Standard colour white, other colours (similar RAL) available on request
Embossing	Name stamping available
Logo	Imprint with your name or logo (unicolour or multicolour)

Delineator (S) type Future (with safety pin)

BAST tested

Delineator (S) 40x40 mm and safety pin.

302.605021.00.01	Delineator Future S with film class RA1 double-sided right/left
302.605022.00.01	Delineator Future S with film class RA1 single-sided right or left
302.605021.00.02	Delineator Future S with film class RA2-B double-sided right/left
302.605022.00.02	Delineator Future S with film class RA2-B single-sided right or left

packaging unit delineators: Euro-pallet = 75 pieces

Accessories:

900.605020.00.01	Replacement safety pin for Future S delineator for fixing the delineator in WEMAS base plate (pic. 1)
900.000031.00.00	Replacement split tube

packaging unit accessories: each 10 pieces



safety pin (pic. 1)



Future lamp (pic. 2)



MB-TL base plate (pic. 3)

BAST tested

with base plates and lamps:
WEMAS MB TL 92 (pic. 3) and
delineator lamp type TL Future (pic. 2)
BAST indication number: 99 2K 03/LU

Delineator (D) type Future (with universal swivel adapter)

BAST tested

Delineator (D) with removable swivel adapter W 03

302.605031.00.01	Delineator universal D with film class RA1 double-sided right/left
302.605032.00.01	Delineator universal D with film class RA1 single-sided right or left
302.605031.00.02	Delineator universal D with film class RA2-B double-sided right/left
302.605032.00.02	Delineator universal D with film class RA2-B single-sided right or left

packaging unit delineators: Euro-pallet = 75 pieces

Accessories:

302.605000.00.02	Swivel adapter inner part for tube (pic. 1)
302.605000.00.01	Swivel adapter outer part for base plate (pic. 2)
900.000031.00.00	Replacement split tube for delineator type 40

packaging unit accessories: each 10 pieces



1
2



Lamp 4000 (pic. 3)



TL 90/91 (pic. 4)



Future Lamp (pic. 5)



MB-TL base plate (pic. 6)

BAST tested

with base plates and lamps:
MB TL 92 (pic. 6) with delineator lamp type TL
Future (pic.5) and WEMAS TL 90/91 (pic. 4) with lamp
type 4000 (pic. 3),
BAST indication number: 02 2K 07, 02 2K 08, 02 2K 15

Delineator (B) type 60



Base plate TL 90/91 (pic. 1)

Delineator (B) 60x60 mm with connecting piece, reinforcement and aglet for protection.

302.605041.00.01	Delineator 60 (B) with film class RA1 double-sided right/left
302.605042.00.01	Delineator 60 (B) with film class RA1 single-sided left or right
302.605042.00.02	Delineator 60 (B) with film class RA2-B single-sided left or right
302.605041.00.02	Delineator 60 (B) with film class RA2-B double-sided right/left
packaging unit: EUR-pallet = 60 pieces	

BAST tested

with base plate
WEMAS TL 90/91 (pic. 1)

BAST identification number: 94 2K 012

WEMAS direction sign delineator

NEW



example of use



Example of use of rule plan B 1 / 7

Delineator with traffic sign (VZ) 222-20 consisting of delineator with traffic sign from HDPE with sign no. 222-20.

According to RSA part B no. 2.2.3 and RSA part B Nr. 2.5.1.

302.605032.90.01	Delineator with traffic sign film class RA1 - single-sided right
900.000012.90.02	Surcharge for delineator with sign and film RA2-B
302.605032.00.91	Traffic sign with film class RA1 right
302.605033.00.51	Delineator with film class RA1 - single-sided right sign no. 605-20
301.003010.00.00	WEMAS base plate TL erection aid type K1 according to TL-erection aid 97 for assembling signs. Weight approx. 38 kg
301.003020.00.00	WEMAS base TL erection aid Typ K2 according to TL-erection aid 97 for assembling signs. Weight approx. 55 kg (1200x400x120mm LxBxH). For highways.

Please choose between film class RA1 or RA2-B as well as film with arrow!
Standard with support for tube 40x40 mm.
Surcharge for support of swivel adapter and hinged joint.

Collapsible delineator (L1) and (L2) type 750

Collapsible delineator (L1) 750 mm high, with high quality base plate from elastomers. Weight approx. 13 kg.

302.605081.10.11	Collapsible delineator (L1) type 750 yellow with film class RA1 double-sided right/left
302.605082.10.11	Collapsible delineator (L1) type 750 yellow with film class RA1 single-sided right or left
302.605081.10.12	Collapsible delineator (L1) Typ 750 yellow with film class RA2-B double-sided right/left
302.605082.10.12	Collapsible delineator (L1) Typ 750 yellow with film class RA2-B single-sided right or left

packaging unit: 10 pieces

Collapsible delineator (L2) 750 mm high, delineator white or yellow with black base plate from 100% recycling material. Weight approx. 11 kg.

302.605081.00.11	Collapsible delineator (L2) type 750 with film class RA1 double-sided right/left
302.605082.00.11	Collapsible delineator (L2) type 750 with film class RA1 single-sided right or left
302.605081.00.12	Collapsible delineator (L2) type 750 with film class RA2-B double-sided right/left
302.605082.00.12	Collapsible delineator (L2) type 750 with film class RA2-B single-sided right or left

packaging unit: 10 pieces



BAST tested
identification no. V5-58/08
according to TL-delineators



- especially stable through 4 rubber plugs
- easy handling
- available with standard film or film with arrow symbol
- body available in white or yellow



hinge



handle base plate



Storage and transport rack for 15 collapsible delineators with additional pretection (see page 23)

WEMAS collapsible delineator type 750

WEMAS collapsible delineators are available in 2 versions. The version in yellow comprises a high quality yellow elastomers base plate as well as a yellow body. The collapsible delineator (L2)white* comprises a black base plate from recycling material. The films are high quality and reflective in class RA1 as well as RA2 B and are available in several colours red/white as well as red/yellow.

The collapsible delineator provides particularly sturdy hinges. You can handle the collapsible delineator easily through the grip on the top of the delineator as well as the grip in the base plate.

Dimensions:

Film: 750 x 187,5 mm (H x B)

Total: 1000 x 240 x 50 mm (H x B x T)

Base plate: 40 x 310 x 640 mm (H x B x T)

*also available in other colours (i.e. yellow)

Delineator type E60

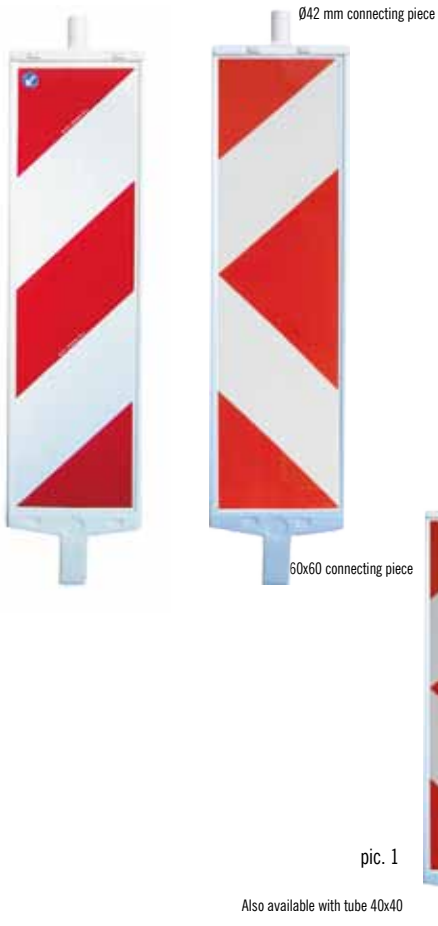

Delineator(E6) with connecting piece 60 x 60 mm for more stability in standard base plates and Ø42 mm connecting piece for lamps, without reinforcement*.
Dimensions of the film: 1000x250mm.

302.605051.00.00	Delineator type E60 with film class RA1 double-sided right/left
302.605052.00.00	Delineator type E60 with film class RA1 single-sided right or left
302.605051.00.02	Delineator type E60 with film class RA2-B double-sided right/left
302.605052.00.02	Delineator type E60 with film class RA2-B single-sided right or left
302.605050.x	Delineator type E60 with reinforcement from steel or aluminium 40x40 (pic. 1)

packaging unit: EUR-pallet = 80 pieces
 Minimum order quantity in other colours = 500 pieces

Accessories:

900.000041.00.00	Replacement reinforcement for delineator type E60 40x40mm approx. 1115 mm long
------------------	--

packaging unit accessories: each 10 pieces

* Surcharge for support tube



Reversible delineator type W60



stacked delineators now **without** space between

- Now 22 mm protection board for the film
- 60 mm frame around the body
- Also stackable with the old version
- stable connecting piece on both sides approx. 8,5 mm

Reversible delineator type W60 with 60 x 60 connecting piece (without reinforcement).
The unique advantage of the reversible delineator is provided by the 60 x 60 mm connecting piece. The reversible delineator which is laminated one side can also be used as a left or right-hand signal by simply turning it around.

302.606051.00.00	Delineator W 60 with film class RA1 double-sided right/left
302.606052.00.00	Delineator W 60 with film class RA1 single-sided right or left
302.606053.00.00	Delineator W 60 with film class RA2-B double-sided right/left
302.606054.00.00	Delineator W 60 with film class RA2-B single-sided right or left

packaging unit: 60 pieces
 Minimum order quantity in other colours = 500 pieces

Accessories:

900.000045.00.00	Replacement reinforcement for delineator type 60 W 40x40mm approx. 1345 mm long
------------------	---

packaging unit accessories: each 10 pieces

* Surcharge for support tube



Available in several colours like orange, blue, green, yellow or red

Delineator type E 40

Delineator (E40) with connecting piece 40 x 40 mm and reinforcement.
Film dimensions 1000x250mm. Connecting piece for lamps (40x40 mm) with drill.

302.605011.00.00	Delineator E40 with film class RA1 double-sided right/left
302.605012.00.00	Delineator E40 with film class RA1 single-sided right or left
302.605011.01.02	Delineator E40 with film class RA2-B double-sided right/left
302.605012.01.02	Delineator E40 with film class RA2-B single-sided right or left

packaging unit: EUR pallet = 75 pieces



Reversible delineator type W40

Reversible delineator double-sided with connecting piece 40 x 40 and reinforcement.
The reversible delineator which is laminated one side can also be used as a left or right-hand signal by simply turning it around.

302.605155.00.01	Delineator type W40 with film class RA1 double-sided right/left
302.605155.01.01	Delineator type W40 with film class RA1 single-sided right or left
302.605155.02.01	Delineator type W40 with film class RA2-B double-sided right/left
302.605155.03.01	Delineator type W40 with film class RA2-B single-sided right or left

packaging unit: EUR-pallet = 75 pieces
 Minimum order quantity in other colours = 500 pieces



Delineator type Benelux huge



Delineator, film dimensions 1100 x 300 mm, with connecting piece 60 x 60 mm and reinforcement (40x40mm).

302.605121.00.01	Type Benelux huge with film class RA1 double-sided right/left
302.605122.00.01	Type Benelux huge with film class RA1 single-sided right or left
302.605121.00.02	Type Benelux huge with film class RA2-B double-sided right/left
302.605122.00.02	Type Benelux huge with film class RA2-B single-sided right or left

packaging unit: pallet = 48 pieces

Delineator type Benelux - small



Delineator (small) film dimensions 1000 x 70 mm, with connecting piece 40 x 40 mm, and reinforcement.

302.605121.70.01	Delineator (small) type Benelux with film class RA1 double-sided right/left or film with horizontal stripes
302.605122.70.01	Delineator (small) type Benelux with film class RA1 single-sided right or left or film with horizontal stripes
302.605121.70.02	Delineator (small) type Benelux with film class RA2-B double-sided right/left or film with horizontal stripes
302.605122.70.02	Delineator (small) type Benelux with film class RA2-B single-sided right or left or film with horizontal stripes

packaging unit: pallet = 200 pieces

Delineator type 500

Delineator with film 500 x 250 mm, with connecting piece 40 x 40 mm without reinforcement

302.605091.00.00	Type 500 film class RA1 double-sided right/left
302.605092.00.00	Type 500 film class RA1 single-sided right or left
302.605091.00.02	Type 500 film class RA2-B double-sided right/left
302.605092.00.02	Type 500 film class RA2-B single-sided right or left
packaging unit: 75 pieces	

Details for version with screw (used on concrete walls) on request



Mit Verschraubung für Betonschutzwände (M20)

Warning signs for guard rails

Warning sign 500 mm, with connecting piece 40x40 mm or screw M20.

302.605102.00.01	Warning sign film class RA1 double-sided right/left	(packaging unit 200 pieces)
302.605102.00.02	Warning sign film class RA2-B double-sided right/left	(packaging unit 200 pieces)
Details for version with screw (used on concrete walls) on request		
302.605000.00.02	Swivel adapter inner section with tube (pic. 1) for warning sign	(packaging unit 100 pieces)
302.605000.00.01	Swivel adapter outer part for base plate (pic. 2)	(packaging unit 100 pieces)



Accessories for delineators

Accessories for WEMAS delineators - Name print placed in the body of the delineator, Logo printed on the film

302.000001.00.00	Cliché for delineators
302.000002.00.00	Printing costs for delineators
301.000002.00.10	Embossing plate for name printing for delineators
301.000001.00.10	Embossing costs per delineator
	Name/logo multicolour on the film

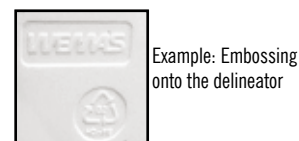

Example: Embossing onto the delineator

302.605000.00.00	Storage and transport rack stackable construction to stock of 100 delineators type Future/40 or 92 delineators type Future "D" or 76 delineators type 60 (pic. 1)
302.605001.00.01	Storage and transport rack stackable construction to stock 15 collapsible delineators (pic. 2)
302.605001.00.00	Storage and transport rack stackable construction to stock 30 collapsible delineators (as pic. 2, but twice)
packaging unit: each 1piece	



WEMAS safety barriers

WEMAS
TOP-PRODUCT

PARTUCULAR IDENTIFICATION OF SAFETY BARRIER FUTURE:

- Testet according to TL Absperrschranken 97
- Easy and fast handling
- Top barrier and epidermal ridge with reflective film
- Long life term through impact resistant material
- connecting pieces for warning lamps
- Other colours available on request
- By return recycling without charge
- Weight 18 kg
- Especially flexible
- Usable with WEMAS base plates
- To connect with WEMAS- connecting clip



WEMAS safety barrier type FUTURE

- tested according to TL Absperrschranken 97-

from HDPE, with reflective film class RA1, Standard colour white, other colours on request, tested according Ziff.2.1.2 ff. of TL-Absperrschranken 97 and fixed connecting pieces for securely mounting warning lamps

305.460431.16.01 Safety barrier Future with film class RA1
1600x1000 mm, identification no.: 20/01 K

305.460432.20.01 Safety barrier Future with film class RA1
2000x1000 mm, identification no.: 20/02 K

packaging unit: 10 pieces

Surcharge for film class RA2-B
Also available without film

Delivery without base plates.

We advise to use our big foot with approx. 36 kg.

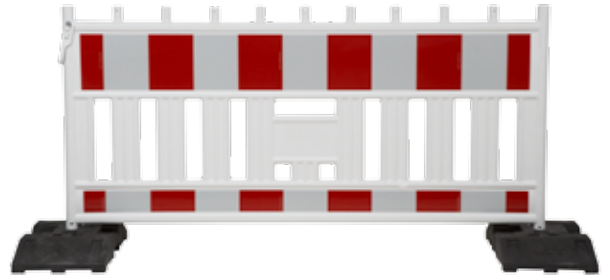

Connecting clip



big foot approx. 36 kg

Barriers



WEMAS partial and complete closure

from HDPE, with reflective film class RA1, Standard colour white, with integrated lamp housings, electrics and battery compartment. The use of air/oxygen batteries ensures a particularly long illumination period and a steady warning light (4 batteries (2x2 6V)).

305.461002.20.01 partial closure Future "yellow"
2000x1000 mm, with integrated yellow lamp housings

305.461001.20.01 complete closure Future "red"
2000x1000 mm, with integrated red lamp housings
packaging unit: 1 piece

Surcharge for film class RA2-B.
Also available without film.

Delivery without base plates.

We advise to use our big foot with approx. 36 kg.

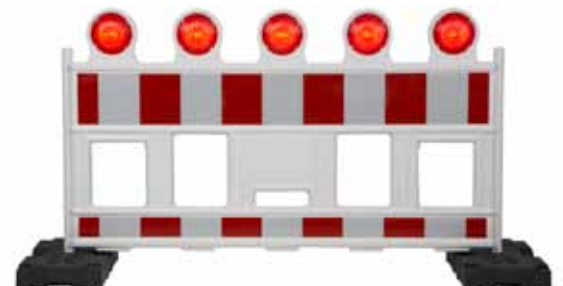
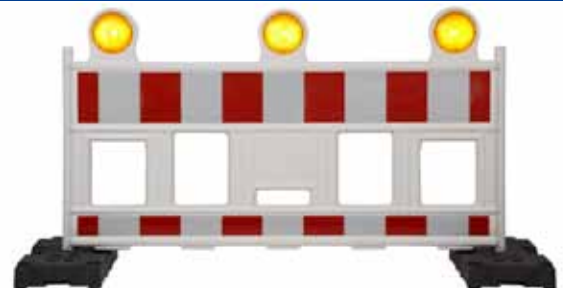

Mobile barrier type „Blitz”

- tested according to TL Absperrschranken 97-

NEW

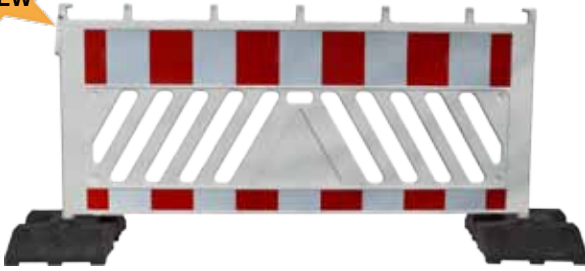

Connecting clip



big foot 301.003010.00.00

from HDPE, with reflective film class RA1, standard colour white, other colours on request, fixed connecting pieces for securely mounting warning lamps.
Delivery includes connecting clip.

305.460433.20.01 Mobile barrier type „Blitz” - white - with film class RA1 - 2000x1000 mm (packaging unit 10 pieces)

Packaging unit: 10 pieces

Surcharge for film class RA2-B
Also available without film covering

Delivery without base plates.
We advise to use our big foot with approx. 36 kg.

Mobile barrier with lamp holder

- tested according to TL Absperrschranken 97-

NEW

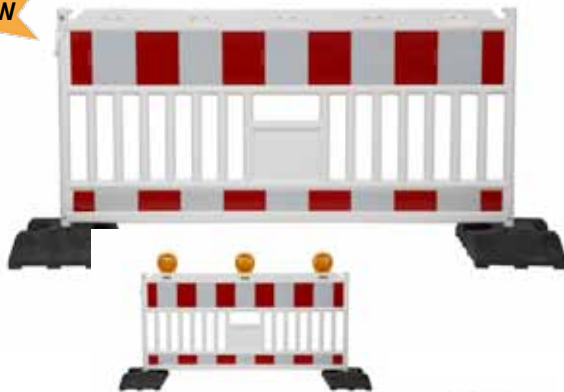

Connecting clip



big foot 9301.003010.00.00

from HDPE, with reflective film class RA1, standard colour white, other colours on request. Delivery includes connecting clip.

305.460532.20.01 Mobile barrier with lamp holder - white- with film class RA1 - 2000x1000 mm

Packaging unit: 10 pieces

Surcharge for film class RA2-B
Also available without film covering

Delivery without base plates.
We advise to use our big foot with approx. 36 kg.

Mobile Event-Barrier

NEW

with handrail

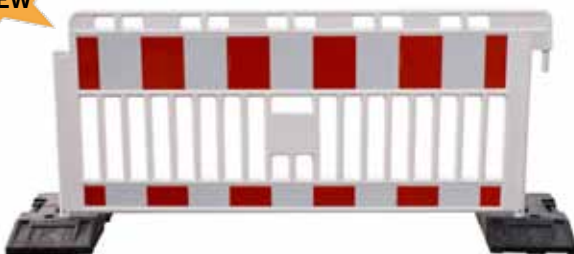

big foot 301.003010.00.00

from HDPE, with reflective film class RA1, standard colour white, other colours on request. Film can be fixed on both sides. It contains a handrail.

305.460632.20.01 Event-Barrier - white - with handrail and film class RA1 - 2000x1000 mm

305.460632.20.01 Event-Barrier - white - with handrail without film

Packaging unit: 10 pieces

Surcharge for film class RA2-B

Delivery without base plates.
We advise to use our big foot with approx. 36 kg.

WEMAS accessories for mobile barriers

308.470001.02.00	Insert for base plates zinc coated for fixing safety barriers (pic. 1)	(packaging unit 10 pieces)
308.047000.02.00	Base for mobile barriers (pic. 2)	(packaging unit 20 pieces)
900.460000.00.06	Replacement connecting piece from HDPE available in several colours (pic. 3) (registered design)	(packaging unit 50 pieces)
305.460900.00.00	Replacement pin for WEMAS barriers (pic. 4), available in several colours.	(packaging unit 50 pieces)
302.000001.00.00	Cliché	
302.000002.00.00	Printing costs	
301.000002.00.00	Embossing plate for name printing on the body of the barrier (pic. 5)	
301.000001.00.00	Embossing costs	



pic.1



pic.2

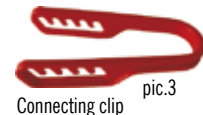

Connecting clip

pic.3

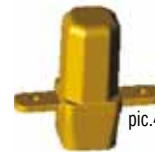

pic.4



pic.5

Storage and transport rack UNIVERSAL for all barriers

308.047001.20.11	Storage and transport rack construction to stock 20 barriers with width 1,60 m and 2,00 m
308.047001.24.11	Storage and transport rack construction to stock 20 barriers with width 1,60 m, 2,00 m and 2,40 m
308.047001.20.10	Storage and transport rack construction to stock 20 barriers with width 1,60 m; 2,00 m (supports are not included)
308.047001.24.10	Storage and transport rack stackable construction to stock 20 barriers with width 1,60 / 2,00 m and 2,40 m (supports are not included)
308.047000.01.00	Support for stackable storage and transport rack
packaging unit: 1 piece	

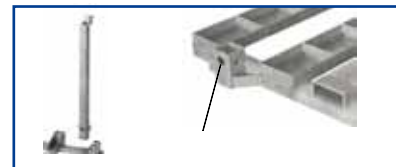

Storage and transport rack for barriers FUTURE

308.047000.00.04	Storage and transport rack stackable construction to stock 20 barriers (only 2 m) 1,225 x 2,0 x 1,10 m (LxHxW), Weight approx. 41 kg
packaging unit: 1 piece	



WEMAS mobile barrier type Vario

- tested according to TL Absperrschranken 97 -

from zinc coated steel panels, with film class RA1. Tested according to TL-Absperrschranken 97.	
305.460131.16.01	Barrier type Vario 1600x1000 mm TL identification no.: 18/01
305.460132.20.01	Barrier type Vario 2000x1000 mm TL identification no.: 19/01
305.460134.24.01	Barrier type Vario 2400x1000 mm
Surcharge for film class RA2 B Also available without film covering	
packaging unit: 10 Pieces	

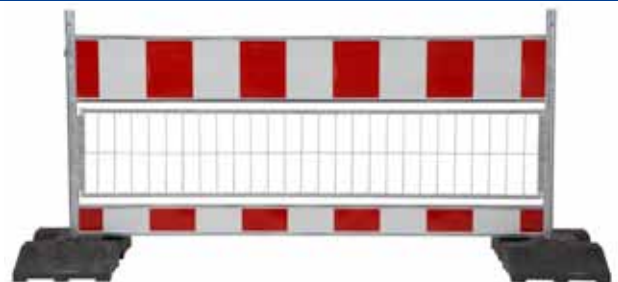

Delivery without base plates.

WEMAS BARRIERS

WEMAS
TOP-PRODUCT

- Tested according to TL Absperrschranken 97
- Easy and fast handling
- Top barrier and epidermal ridge with reflective film
- Long life term through impact resistant material
- Connecting pieces for warning lamps
- Other colours available an request
- By return recycling without charge

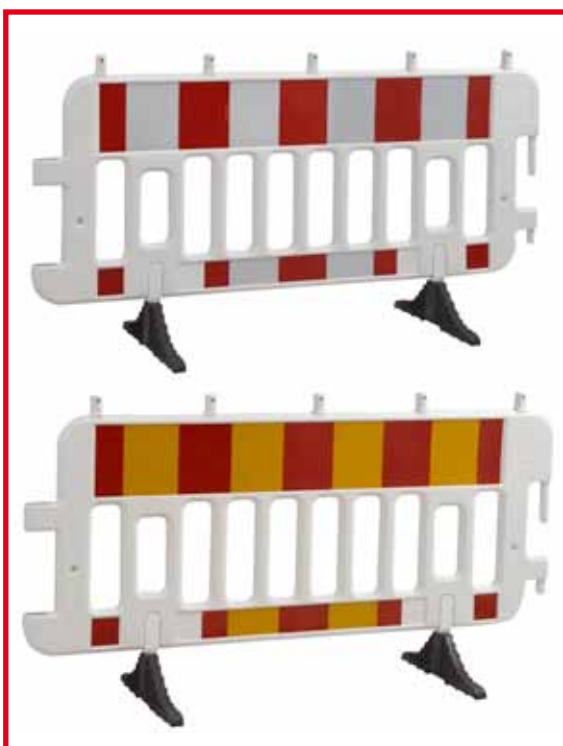

PARTUCULAR IDENTIFICATION OF WEMAS BARRIERS:

- Total weight only 19 kg
- Fixing without screws
- Turnable feets included also available with base plate adapter and heavy base plate
- Standard with 2 hooks/eyelets
- Better standing by using the base plate MB TL 92



WEMAS barrier

- tested according to TL Absperrschranken 97-

from HDPE, with reflective film class RA1, standard colour white, other colours available on request, tested according to No. 2.1.2 ff. of TL-Absperrschranken 97. Secure and simply erection thanks to the integrated feet and 2 hooks/eyelets ensures easy connection. With blown fixed connecting piece for secure mounting of warning lamps.

305.560433.16.01	Barrier from HDPE with turnable feet 1600x1000 mm	(packaging unit 10 pieces)
305.560433.20.01	Barrier from HDPE with turnable feet 2000x1000 mm, identification no.: GA 0303/06	(packaging unit 10 pieces)
305.560443.16.01	Barrier from HDPE with adapter for base plates 1600x1000 mm	packaging unit 10 pieces)
305.560443.20.01	Barrier from HDPE with adapter for base plates 2000x1000 mm, identification no.: GA 0303/06	(packaging unit 10 pieces)
packaging unit: 10 pieces		

Surcharge for film class RA2-B.
Also available without film covering.

1. Standard with turnable feet
2. with adapter for base plates (pic. 1)



Barriers

WEMAS barrier EXPORT

from HDPE, with reflective film class RA1, standard colour white, other colours available on request, with 2 integrated hooks/eyelets. Standard with turnable feet, also available with adapter for WEMAS base plates.

305.560431.16.01	Barrier EXPORT with turnable feet 1600x1000 mm, white with film class RA 1
305.560432.20.01	Barrier EXPORT with turnable feet 2000x1000 mm, white with film class RA 1 RA1
packaging unit: 45 pieces	

Also available without film covering.

1. Standard with turnable feet
2. with adapter for base plates

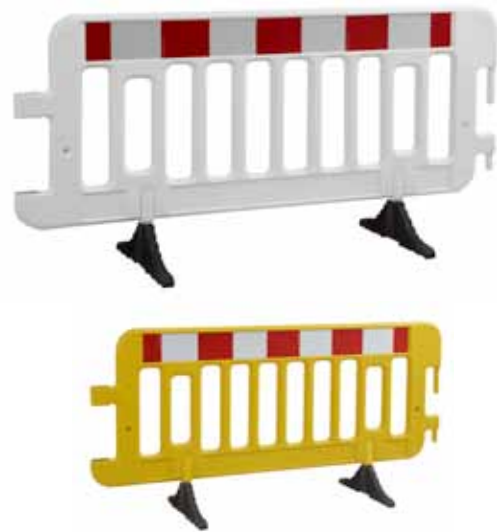

WEMAS curve warning barrier

from HDPE, with reflective film class RA1, standard colour white, other colours available on request with hook/eyelet connection. Standard with turnable feet, also available with adapter for WEMAS base plates.

305.560633.20.01	Curve barrier with film class RA1 2000x1000 mm, with turnable feet
305.560633.20.01	Curve barrier with film class RA1 2000x1000 mm, with adapter for base plates
packaging unit: 5 pieces	

Surcharge for film class RA2-B.
Base plates has to be ordered seperately.



Curve barrier with adapter for base plates,
also available with other bases!

WEMAS accessories for barriers



Replacement feet from recycling PVC (black) or high quality elastomers (coloured) with corresponding coloured adapter

305.560000.00.02	Replacement feet for barriers (recycling PVC) (pic. 1) incl. adapter
305.560000.00.01	Replacement feet for barriers (coloured elastomers) (pic. 2) incl. corresponding coloured adapter
305.560000.00.12	Replacement feet for barriers (pic. 3) for WEMAS base plates
305.460900.00.00	Replacement pin for WEMAS barriers (pic. 4) various colours available.

packaging unit: 1 piece

Storage and transport rack for barriers

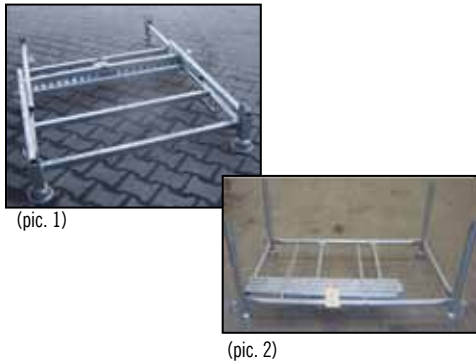

from hot zinc dipped steel, stackable for each max. 20 barriers

308.047100.00.00	Storage and transport rack for barriers 1,60 and 2,00 m- stackable - with hinged support (pic. 1)
308.047100.00.01	Storage and transport rack for barriers 2,00 m- stackable (pic. 2)

packaging unit: 1 piece

WEMAS demo barrier



from hot zinc dipped raw material, stackable, with hook/eyelet and removable feet (outer pin Ø 32 mm, stick Ø 16 mm).

308.048101.00.00	Dimensions: 2000x1000 mm 13 sticks Weight 15,5 kg
308.048102.00.00	Dimensions: 2400x1000 mm 15 sticks Weight 22,5 kg

packaging unit: 10 pieces

308.048103.00.01	Replacement feet „small” for demo barrier screwed
308.048104.00.01	Replacement feet „tall” for demo barriers screwed

packaging unit: 1 piece

Barrier type New Jersey

from ultraviolet resistant HDPE as blown hollow body in white and red. Fillable with water or sand, easy connected for traffic division.

Holes 60x60mm, also available with WEMAS swivel adapter for fixing warning signs. Weight approx. 9,5 kg.

302.100050.01.00 Barrier type New Jersey incl. connection
1185x520 mm, white

302.100050.02.00 Barrier type New Jersey incl. connection
1185x520 mm, red

302.605102.00.02 Warning sign with film class RA2-B
double-sided right/left

packaging unit: 10 pieces



Example with small and flexible delineator

WEMAS Manhole barrier

WEMAS
TOP-PRODUCT

- Dimensions according to ZTV-SA 97
- Easy and fast handling
- with reflective film
- Long life term through impact resistant material
- Other colours available on request
- By return recycling without charge
- NEW with hinges (optional as accessory)



PARTUCULAR IDENTIFICATION OF WEMAS MANHOLE BARRIERS:

- Only approx. 7 kg per element
- To be connected without screws
- Easy assembling with 4 or more elements

Manhole barrier "Blitz" - 1000 mm high

from HDPE, with reflective film class RA1, form and image according to TL Absperrschranken 97, dimensions according to ZTV-SA 97.
Standard colour white, other colours on request, consisting of 4 elements with hook and eyelet connection.

308.049111.00.01	Manhole barrier with film class RA 1 1250x1250 mm, 1,0 m high
308.049110.00.01	Manhole barrier single element
305.560900.00.00	Hinge for manhole barrier (standard colour black) as accessory
	Surcharge for film class RA2-B Also available without film



Manhole barrier "Blitz-small" - 750 mm high

from HDPE, with reflective film class RA1,
Standard colour white, other colours on request, consisting of 4 elements with hook and eyelet connection.

308.049112.00.01	Manhole barrier with film class RA 1 4 x 1250x1250 mm, 0,75 m high
308.049112.00.01	Manhole barrier single element 1250x1250 mm, 0,75 m high
305.560900.00.00	Hinge for manhole barrier (standard colour black) as accessory
	Surcharge for film class RA2-B Also available without film



WEMAS manhole barrier steel

- tested according to TL Absperrschranken 97 -

from zinc coated steel with reflective film class RA1, consisting of 4 elements,
hinged, form and image according to TL Absperrschranken 97, Dimensions according to ZTV-SA 97.

308.049101.00.00	Manhole barrier steel 1000x1000 mm
308.049102.00.00	Manhole barrier steel 1500x1500 mm
308.049103.00.00	Manhole barrier steel 2000x2000 mm
	Surcharge for film class RA2-B

packaging unit: 1 piece



WEMAS steel tubes for fences



pic. 1 pic. 2

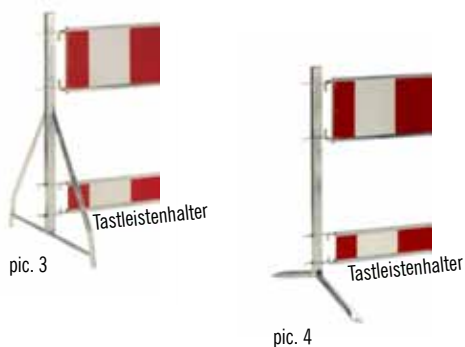

pic. 3

pic. 4

Steel tubes 40x40mm with connections made from plastics, to use with wemas bases

305.053001.00.00 Type A 2 for one fence
(pic. 1)

305.053002.00.00 Type A 4 for two fences
(pic. 2)

packaging unit: 50 pieces

Steel tubes 40x40mm with feet

308.051002.00.00 Type B 2 for one fence
(like pic. 3 without a 2nd. connection)

308.051004.00.00 Type B 4 for two fences (pic. 3)

308.052002.00.00 Type D 2 for one fence
(like pic. 4 without a 2nd. connection)

308.052004.00.00 Type D 4 for two fences (pic. 4)

packaging unit: 50 pieces

WEMAS fences 250 mm height

- tested according to TL Absperrschranken 97 -



Detailbild: Endpieces Nr. 1



made from steel with reflex film class RA1

305.060030.12.10 fence 250 - 1200 mm
Endpieces Nr. 1

305.060031.16.11 fence 250 - 1600 mm
Endpieces Nr. 1, Test-No.: 01/98

305.060032.20.11 fence 250 - 2000 mm
Endpieces Nr. 1, Test-No.: 01/98

305.060034.24.11 fence 250 - 2400 mm
Endpieces Nr. 1, Test-No.: 01/98

305.060036.28.10 fence 250 - 2800 mm
Endpieces Nr. 1

305.060038.32.10 fence 250 - 3200 mm
Endpieces Nr. 1

Also available with film class RA2-B

packaging unit: 25 pieces

WEMAS fence 500 mm height

- approved TL Absperrschranken 97 -

made from steel with reflex film class RA1

305.060033.20.11 fence 500, 2000 mm length
End pieces No. 1

305.060035.24.11 fence 500, 2400 mm length
End pieces No. 1

Also available with film class RA2-B

packaging unit: 6 Pieces



ABSPERRGITTER/SCHRANKEN

WEMAS fence 100 mm height

made from steel with reflex film class RA1

305.060010.12.00 fence 1200 mm length

305.060011.16.01 fence 1600 mm length
Test-No.: 07/98

305.060012.20.01 fence 2000 mm length
Test No.: 08/98

305.060014.24.01 fence 2400 mm length
Test No.: 09/98

305.060016.28.00 fence 2800 mm length

305.060018.32.00 fence 3200 mm length

packaging unit: 25 Pieces



WEMAS Storage and Transport Rack for fences

305.060000.00.00 Storage and Transport rack for WEMAS fences, max.
50 pcs.

packaging unit: 1 Pieces



WEMAS WARNING LIGHT/DELINEATOR LAMPS

TL-FUTURE + TL-2000

- BAST-tested according to TL Warnleuchten 90 and EN 12352 as well as TL Leitbaken 97
- Particularly economic due to the long span of life
- Low power drain because of the LED lamp
- Lamp housing available in different colours



WEMAS quality Made in Germany: Resistant housings and robust, removable spare parts ensure a long span of life.



TL delineator lamp FUTURE

TL-Future LED warning light with double or single light. Standard housing colour yellow, other colours on request. Also available with flash electronic. Can be fixed with lamp holder (pic. 1) or to be fixed and screwed (40x40 or Ø42 connecting piece).

conform to EN 12352 - L6



Other housing colours available.

303.019020.18.10	TL-Future LED, Ø 180 mm identification no.: V4-27-2003 double-sided light yellow
303.019020.18.20	Future LED, Ø 180 mm double-sided light red
303.019020.18.12	TL-Future LED, Ø 180 mm identification no.: V4-28-2003 single-sided light yellow
303.019020.18.22	TL-Future LED, Ø 180 mm identification no.: V4-31-2003 double-sided light red
packaging unit: 12 pieces	

flash light

303.019030.18.10	Future, flash Ø 180 mm single-sided light yellow
303.019030.18.11	Future, flash Ø 180 mm double-sided light yellow
packaging unit: 1 piece	

- BAST tested
- with one or two batteries possible, low power drain
- stable and shatter-proof
- can be connected with screw
- resistant against oil, frost, salt
- easy removable electronic
- standard colour yellow, other colours available
- particularly economic due to the long span of life

Warning lamps

TL warning light type 2000

TL-2000 LED warning light with double or single light. Standard housing colour yellow, other colours on request. Also available with flash electronic. Can be fixed with lamp holder (pic. 1) or to be fixed and screwed (40x40 or Ø42 connecting piece).

conform to EN 12352 - L6



Warning light 2000 not approved for delineators

303.017020.18.10	TL-2000 LED, Ø 180 mm identification no.: V4-126-2003 double-sided light yellow
303.017020.18.20	2000 LED, Ø 180 mm double-sided light red
303.017020.18.12	TL-2000 LED, Ø 180 mm identification no.: V4-126-2003 single-sided light yellow
303.017020.18.22	TL-2000 LED, Ø 180 mm identification no.: V4-125-2003 single-sided light red
packaging unit: 12 pieces	

flash light

303.017030.18.10	2000, flash Ø 180 mm single-sided light yellow
303.017030.18.11	2000, flash Ø 180 mm double-sided light yellow
packaging unit: 1 piece	

- BAST tested
- with one or two batteries possible, low power drain
- stable and shatter-proof
- can be connected with screw
- resistant against oil, frost, salt
- easy removable electronic
- standard colour yellow, other colours available
- particularly economic due to the long span of life



TL delineator light type 4000

BAS^t tested



303.021020.18.11	TL-4000 LED, Ø 180 mm identification no.: V4-30-2003 double-sided light yellow
303.021021.18.11	4000 LED, Ø 180 mm double-sided light red
packaging unit: 12 pieces	

flash light

900.610000.18.10	TL-4000 flash, Ø 180 mm double-sided light yellow	(packaging unit 1 piece)
302.605203.00.00	Replacement cable 1,60 m with plug connector	(packaging unit 10 pieces)

Warning lamps type Export



Warning lamps for several functions with housings for one or two 6 V batteries, with assembled holder.

303.017020.16.10	2000 LED, Ø 160 mm (pic. 1) double-sided light yellow
303.017020.16.20	2000 LED, Ø 160 mm (pic. 2) double-sided light red
303.017011.16.20	2000 LED, Ø 160 mm double-sided light red/white
packaging unit: box each 12 pieces	

303.016020.11.10	1001 LED yellow with Ø 110 mm lense and 4 LED
303.016020.11.10	1001 LED orange triangle with Ø 110 mm lense, yellow and 4 LED (pic.4)
303.016020.16.10	1000 LED yellow Ø 160 mm (pic. 5) double-sided light yellow
303.016020.16.20	1000 LED yellow Ø 160 mm (as pic.5) double-sided light red
packaging unit: box each 12 pieces	

Delineator lights type 5000



303.022011.18.11	TL-5000, Ø 180 mm housing without electronic yellow light	(packaging unit 12 Pieces)
302.605203.00.00	Replacement cable 1,60 m with plug connector	(packaging unit 10 Pieces)

Warning lamp type 6000



303.023000.34.10	6000 Ø 340 mm complete but without electronic
303.023011.34.10	6000, Ø 340 mm Halogen 12-24 V
303.023031.34.10	6000, Ø 340 mm Xenon flash 12-24 V
303.023041.34.10	6000, Ø 340 mm 24 V-230 V
303.023011.34.11	6000, Ø 340 mm LED 12-24 V
packaging unit: 1 piece	

Warning lamp type 7000

303.020030.18.10	7000 flash, Ø 180 mm double-sided light yellow	(packaging unit 1 piece)
------------------	---	-----------------------------



hand lamps

390.025000.00.00	Hand lamp Krypton suitable for 6 V batteries 4 R 25	(packaging unit 24 pieces)
390.025000.00.01	Hand lamp with 8 LED suitable for 6 V batteries 4 R 25	(packaging unit 24 pieces)
390.025000.00.04	Hand lamp with 13 LED suitable for 6 V batteries 4 R 25	(packaging unit 24 pieces)



Batteries and accessories

Batteries environmentally friendly, without mercury and without cadmium

304.036001.00.00	Zinc / carbon 4 R 25 6 V, 7 Ah -blue- (pic. 1) Pallet 1.536 pieces	(packaging unit 24 pieces)
304.036001.00.02	Zinc / carbon 4 R 25 6 V, 6 Ah -black- (pic. 2) Pallet 1.536 pieces	(packaging unit 24 pieces)
304.037001.00.00	Air / Alkaline 6 V, 50 Ah (pic. 3) Pallet 1.056 pieces	(packaging unit 12 pieces)
304.040000.00.00	Battery tester for batteries 4 R 25 (pic. 4)	(packaging unit 1 piece)
304.037003.00.00	Air Alkaline 6 V, 120 Ah (pic. 5)	(packaging unit 12 pieces)
304.039000.00.00	Battery box Universal for (pic. 6) 2 batteries 4 R 25 or 50 Ah	(packaging unit 24 pieces)



WEMAS indicator for TL warning lamps and delineator lights



WEMAS warning lamps and delineator lights are equipped with replacing electronic. Replacement for all lamps are listed below:

900.019020.00.10	indicator for Future / WEMAS 2000 (pic. 1) LED yellow	(packaging unit 60 pieces)
900.019020.00.20	indicator for Future / WEMAS 2000 LED red	(packaging unit 60 pieces)
900.019030.18.10	indicator for Future / WEMAS 2000 (pic. 2) Xenon - flash	(packaging unit 1 piece)
303.021000.00.00	indicator for WEMAS 4000LED (pic. 3)	(packaging unit 60 pieces)
900.610002.00.00	indicator for WEMAS 4000 flash	(packaging unit 1 piece)
900.500009.00.00	indicator for WEMAS 5000 (pic. 4) (complete electronic)	(packaging unit 60 pieces)
303.700011.02.00	indicator for WEMAS 7000 (pic. 5)	(packaging unit 60 pieces)
900.700011.01.00	indicator for WEMAS 7000 flash	(packaging unit 1 piece)
302.605203.00.00	Replacement cable 1,60 m with plug connector (pic. 6)	(packaging unit 10 pieces)

WEMAS accessories for warning lamps and delineator lights

900.019017.00.00	Replacement lamp holder (pic. 1)	(packaging unit 50 pieces)
900.019017.00.00	Screw for lamp housing (nut included)	(packaging unit 50 pieces)
900.019011.00.00	Lamp housing lower part (battery bottom) (pic. 2) for Future and WEMAS 2000	
900.000000.20.10	Diffuser Future yellow	
900.000000.20.20	Diffuser Future red	
900.000000.20.40	Diffuser Future crystal clear	
900.000000.10.00	Diffuser crystal clear 180 mm for WEMAS 2000	
900.002000.20.10	Diffuser yellow 180 mm for WEMAS 2000	
900.002000.20.20	Diffuser red 180 mm for WEMAS 2000	
	packaging unit: 10 pieces	
900.000000.20.30	Reflector for Future delineator light provided with thread	
303.030001.00.00	lamp key (pic. 3)	
303.030002.00.00	lamp tool (pic. 4)	
	packaging unit: 12 pieces	
303.000001.00.00	Logo/name print Cliché for lamps	
302.000002.00.00	Printing costs	
900.019017.00.03	Anti-twist protection (2 U-connector) to be fixed on the battery bottom art. Nr 900.019011.00.00 (set each 2 pieces) (pic. 5)	(packaging unit 50 pieces)

1



2



Streuscheiben



3



4



Anti-twist protection:

WEMAS CONES

WEMAS
TOP-PRODUCT

FROM 320 TO 1000 mm

- stackable
- BAST-tested according to TL traffic cone 94 with films class RA1 and RA2-B
- with reflective film, reflective film rings or fluorescent
- one piece cones and two piece cones
- various weights
- PVC cone cold resistant until -39°C and inherently stable until $+60^{\circ}\text{C}$



Vulkan



Molan



Titan

WEMAS Vulkan traffic cone

Vulkan - Cone

The Vulkan cone is available with one component or two components. The two components-cone is consisting from a blown HDPE-body and a base from recycling PVC. That gives our Vulkan cone an extrem high stability. The body is provided with a grip at the upper end.

The one component Vulkan-Cone is from one piece: (cone and base) soft PVC* with grip.

All cones are available in all colours, with or without film.



WEMAS Molan traffic cone

Molan - Cone

The Molan cone is produced by injection molding from soft PVC.

The difference to the titan cone is the shape and strength.

The Molan cone body has a round transition from the body to the base. It has a bigger wall-thickness in the upper area of the cone and also a balanced distribution of weight. Another advantage is the low stacking-height.

The base of the Molan-cone is additionally reinforced with 3mm thick PVC. The Molan-cone is the best cone for road signing because it does not stick on the fresh road marking tape. Also available with a small grip..



WEMAS Titan traffic cone

Titan - Cone

The body of titan-cone is fluorescent and like the Molan-cone produced by injection molding from soft PVC.

The Titan cone is produced with a lighter wall thickness in the upper area of the cone which is even more flexible. The main focus is shifted at the base. This increases the stability.



Our cone-range currently comprises over 60 cones and will be continually extended. It consists of three main groups (Vulkan, Molan, Titan) with 4 sizes and different weights and equipments. In addition, we offer a large number of different similar products. If you don't find the requested products please send us your request for quote. We also could produce customised products in high quality and for low-prices.

We produce the cones with modern machinery. Our production capacity is more than 1.2 Million cones a year. Our machinery contains injection moulding technology, hydraulic blow moulding machines as well as rotation machines. Our terms of delivery are very flexible and efficient. Certainly we will be happy for your individual enquiry.

WEMAS traffic cones 750 mm - reflective film

BAST tested







Description:	Vulkan TL-710-43	Vulkan TL-710-44	Titan TL-610-41	Titan TL-610-44S
Height:	750 mm	750 mm	750 mm	750 mm
Weight / Weight class	approx. 5,80 kg / class 3	approx. 5,80 kg / class 3	4,25 kg / class 2	4,25 kg / class 2
Film/Model:	reflective film class RA1 red/white	reflective film class RA2-B red/white	reflective film class RA1 red/white	reflective film class RA2-B red/white
BAST identification no.:	02 3S 03	02 3S 03	95 S3 02	V4-44/2005
Type:	two-piece with heavy foot	two-piece with heavy foot	one piece	one piece
Material:	HDPE (top piece) PVC (foot)	HDPE (top piece) PVC (foot)	PVC	PVC - Recycling
Colour:	red/orange (top piece) schwarz (foot)	red/orange (top piece) schwarz (foot)	fluorescent orange	black
Characteristics:	stackable removable foot	stackable removable foot	cold-resistant until - 39°C elastic and flexible	elastic and flexible
Packaging unit:	10 pieces	10 pieces	box 10 pieces	box 10 pieces
Item no. :	307.610750.00.01	307.610750.00.02	400.000612.00.00	307.610750.00.32

WEMAS traffic cones 750 mm - reflective stripes



Description:	Molan 330 Lux	Titan 380 Lux	Vulkan 780-43	Vulkan 780-44	Molan 331 Flex
Height:	750 mm	750 mm	750 mm	750 mm	750 mm
Weight / Weight class:	4,20 kg / class 2	3,10 kg	approx. 5,20 kg	5,20 kg	4,20 kg
Film/Model:	two reflective stripes, silver-coloured	two reflective stripes, silver-coloured	two reflective film rings class RA1	two reflective film rings class RA2-B	two reflective film rings class RA1
Type:	one piece	one piece	two-piece with foot	two-piece with foot	one piece
Material:	PVC	PVC	HDPE (top piece) PVC-R (foot)	HDPE (top piece) PVC-R (foot)	PVC
Colour:	fluorescent orange	fluorescent orange	red / orange with white film rings	red / orange with white film rings	fluorescent orange
Characteristics:	cold-resistant until - 39°C elastic and flexible	cold-resistant until - 39°C elastic and flexible	stackable, removable film rings and foot	stackable removable film rings and foot	cold-resistant until - 39°C elastic and flexible
Packaging unit:	box 10 pieces	box 10 pieces	10 pieces	10 pieces	box 10 pieces
Item no.:	400.000006.00.00	400.000025.00.00	307.610750.13.02	307.610750.03.02	400.000331.00.00

WEMAS traffic cones 750 mm - reflective stripes/film

					
Description:	Molan 332 Flex	Titan 381 Flex	Titan 382 Flex	Titan 510	Titan 520
Height::	750 mm	750 mm	750 mm	750 mm	750 mm
Weight / Weight class:	4,20 kg	3,10 kg	3,10 kg	5,10 kg / class 3	5,10 kg / class 3
Film/Model:	two reflective film stripes class RA2-B	two reflective film stripes class RA1	two reflective film stripes class RA2-B	reflective film class RA1 red/white	reflective film class RA2-B red/white
Type:	one piece	one piece	one piece	one piece	one piece
Material:	PVC	PVC	PVC	PVC	PVC
Colour:	fluorescent orange	fluorescent orange	fluorescent orange	fluorescent orange	fluorescent orange
Characteristics:	cold-resistant until - 39°C elastic and flexible	cold-resistant until - 39°C elastic and flexible	cold-resistant until - 39°C elastic and flexible	cold-resistant until - 39°C elastic and flexible	cold-resistant until - 39°C elastic and flexible
Packaging unit:	box 10 pieces	box 10 pieces	box 10 pieces	box 10 pieces	box 10 pieces
Item no.:	400.000332.00.00	400.000381.00.00	400.000382.00.00	400.000121.00.01	400.000121.00.02

WEMAS traffic cones 750 mm - not reflective

					
Description:	Titan 380	Molan 330	Titan 370	Molan 320	Titan 390
Height::	750 mm	750 mm	750 mm	750 mm	750 mm
Weight / Weight class:	3,10 kg	4,20 kg	3,10 kg	4,20 kg	4,20 kg
Film/Model:	with two white stripes not reflective	with two white stripes not reflective	without film	without film	with two black stripes not reflective
Type:	one piece	one piece	one piece	one piece	one piece
Material:	PVC	PVC	PVC	PVC	PVC
Colour:	fluorescent orange day-glow finish	fluorescent orange day-glow finish	fluorescent orange	fluorescent orange	yellow
Characteristics:	cold-resistant until - 39°C elastic and flexible	cold-resistant until - 39°C elastic and flexible	cold-resistant until - 39°C elastic and flexible	cold-resistant until - 39°C elastic and flexible	stackable, flexible
Packaging unit:	box 10 pieces	box 10 pieces	box 10 pieces	box 10 pieces	box 10 pieces
Item no.:	400.000021.00.00	400.000003.00.00	400.000022.00.00	400.000009.00.00	307.610750.05.10

WEMAS traffic cone 500 mm - reflective film

BASt tested







Description:	Vulkan TL-710-40	Vulkan TL-710-41	Titan TL-610-40	Titan TL-611
Height:	500 mm	500 mm	500 mm	500 mm
Weight / Weight class	approx. 2,90 kg / class 3	approx. 2,90 kg / class 3	2,20 kg / class 2	2,80 kg / class 3
Film/Model:	reflective film class RA1 red/white	reflective film class RA2-B red/white	reflective film class RA1 red/white	reflective film class RA1 red/white
BASt identification no.:	02 3F 03	02 3F 02	95 3F 01	95 3F 06
Type:	two-piece with heavy foot	two-piece with heavy foot	one piece	one piece
Material:	HDPE (top piece) PVC (foot)	HDPE (top piece) PVC (foot)	PVC	PVC
Colour:	red/orange (top piece) schwarz (foot)	red/orange (top piece) schwarz (foot)	fluorescent orange	fluorescent orange
Characteristics:	stackable removable foot	stackable removable foot	cold-resistant until - 39°C elastic and flexible	cold-resistant until - 39°C elastic and flexible
Packaging unit:	25 pieces	25 pieces	box 25 pieces	10 pieces
Item no. :	307.610500.00.01	307.610500.00.02	400.000610.00.00	400.000611.00.00

WEMAS traffic cone 500 mm - reflective stripes







Description:	Molan 230 Lux	Titan 280 Lux	Vulkan 780-40	Molan 231 Flex	Molan 232 Flex
Height:	500 mm	500 mm	500 mm	500 mm	500 mm
Weight / Weight class:	1,55 kg	1,45 kg	approx. 2,90 kg	1,55 kg	1,55 kg
Film/Model:	two reflective stripes, silver-coloured	two reflective stripes, silver-coloured	two white reflective film rings class RA1	two white reflective film rings class RA1	two white reflective film rings class RA2-B
Type:	one piece	one piece	one piece	one piece	one piece
Material:	PVC	PVC	HDPE (top piece) PVC-R (foot)	PVC	PVC
Colour:	fluorescent orange	fluorescent orange	red / orange with white film rings	fluorescent orange day-glow finish	fluorescent orange day-glow finish
Characteristics:	cold-resistant until - 39°C elastic and flexible	cold-resistant until - 39°C elastic and flexible	stackable, removable film rings and foot	cold-resistant until - 39°C elastic and flexible	cold-resistant until - 39°C elastic and flexible
Packaging unit:	box 25 pieces	box 25 pieces	25 pieces	box 25 pieces	box 25 pieces
Item no.:	400.000005.00.00	400.000023.00.00	307.610500.13.02	400.000231.00.00	400.000232.00.00

WEMAS Traffic cones 500 mm - reflective stripes/film

					
Description:	Titan 281 Flex	Titan 282 Flex	Titan 280	Titan 280 L	Molan 230
Height:	500 mm	500 mm	500 mm	500 mm	500 mm
Weight / Weight class:	1,25 kg	1,25 kg	1,25 kg	1,05 kg	1,55 kg
Film/Model:	two white reflective film stripes class RA1	two white reflective film stripes class RA2-B	two white film stripes not reflective	two white film stripes not reflective	two white film stripes not reflective
Type:	one piece	one piece	one piece	one piece	one piece
Material:	PVC	PVC	PVC	PVC	PVC
Colour:	fluorescent orange day-glow finish	fluorescent orange day-glow finish	fluorescent orange day-glow finish	fluorescent orange day-glow finish	fluorescent orange day-glow finish
Characteristics:	cold-resistant until - 39°C elastic and flexible	cold-resistant until - 39°C elastic and flexible	cold-resistant until - 39°C elastic and flexible	cold-resistant until - 39°C elastic and flexible	cold-resistant until - 39°C elastic and flexible
Packaging unit:	box 25 pieces	box 25 pieces	box 25 pieces	box 25 pieces	box 25 pieces
Item no.:	400.000281.00.00	400.000282.00.00	400.000017.00.00	400.000015.00.00	400.000002.00.00

WEMAS traffic cones 500 mm - not reflective

				
Description:	Titan 289 yellow	Titan 270	Molan 220	Titan 270 L
Height:	500 mm	500 mm	500 mm	500 mm
Weight / Weight class:	1,25 kg	1,25 kg	1,55 kg	1,10 kg
Film/Model:	yellow stripes not reflective	without film	without film	without film
Type:	one piece	one piece	one piece	one piece
Material:	PVC	PVC	PVC	PVC
Colour:	orange with yellow stripes day-glow finish	fluorescent orange	fluorescent orange	fluorescent orange
Characteristics:	cold-resistant until - 39°C elastic and flexible	cold-resistant until - 39°C elastic and flexible	cold-resistant until - 39°C elastic and flexible	cold-resistant until - 39°C elastic and flexible
Packaging unit:	box 25 pieces	box 25 pieces	box 25 pieces	box 25 pieces
Item no.:	400.000400.00.00	400.000018.00.00	400.000008.00.00	400.000016.00.00

WEMAS traffic cones 320 mm - reflective stripes

					
Description:	Molan 130 Lux	Molan 131 Flex	Titan 180 Lux	Titan 181 Flex	
Height:	320 mm	320 mm	320 mm	320 mm	
Weight / Weight class:	0,85 kg	0,85 kg	0,50 kg	0,50 kg	
Film/Model:	one reflective stripe silver-coloured	one reflective white stripe class RA1	one reflective stripe silver-coloured	one reflective white stripe class RA1	
Type:	one piece	one piece	one piece	one piece	
Material:	PVC	PVC	PVC	PVC	
Colour:	fluorescent orange	fluorescent orange	fluorescent orange	fluorescent orange	
Characteristics:	cold-resistant until - 39°C elastic and flexible	cold-resistant until - 39°C elastic and flexible	cold-resistant until - 39°C elastic and flexible	cold-resistant until - 39°C elastic and flexible	
Packaging unit:	box 25 pieces	box 25 pieces	box 25 pieces	box 25 pieces	
Item no.:	400.000004.00.00	400.000131.00.00	400.000978.00.00	400.000181.00.00	

WEMAS traffic cones 320 mm - not reflective

					
Description:	Molan 130	Molan 120	Molan 130 Colour	Molan 120 Colour	Molan 130 white
Height:	320 mm	320 mm	320 mm	320 mm	320 mm
Weight / Weight class:	0,85 kg	0,85 kg	0,85 kg	0,85 kg	0,85 kg
Film/Model:	one white stripe not reflective	without film	one white stripe not reflective	without film	one black stripe not reflective
Type:	one piece	one piece	one piece	one piece	one piece
Material:	PVC	PVC	PVC	PVC	PVC
Colour:	fluorescent orange	fluorescent orange	other colours on request	other colours on request	white
Characteristics:	cold-resistant until - 39°C elastic and flexible	cold-resistant until - 39°C elastic and flexible	elastic and flexible	elastic and flexible	elastic and flexible
Packaging unit:	box 25 pieces	box 25 pieces	box 25 pieces	box 25 pieces	box 25 pieces
Item no.:	400.000001.00.00	400.000007.00.00	400.0000xx.00.00	400.0000xx.00.00	400.001426.00.00

WEMAS traffic cone 320 mm - nicht reflektierend

					
Description:	Titan 180	Titan 170	Titan 180 Color	Titan 170 Color	„school cone“
Height:	320 mm	320 mm	320 mm	320 mm	200 mm
Weight / Weight class:	0,45 kg	0,45 kg	0,45 kg	0,45 kg	0,25 kg
Film/Model:	one white stripe not reflective	without film	one white stripe not reflective	without film	without film
Type:	one piece	one piece	one piece	one piece	one piece
Material:	PVC	PVC	PVC	PVC	PVC
Colour:	fluorescent orange	fluorescent orange	other colours on request	other colours on request	fluorescent orange
Characteristics:	cold-resistant until - 39°C elastic and flexible	cold-resistant until - 39°C elastic and flexible	elastic and flexible	elastic and flexible	cold-resistant until - 39°C elastic and flexible
Packaging unit:	box 25 pieces	box 25 pieces	box 25 pieces	box 25 pieces	box 25 pieces
Item no.:	400.000013.00.00	400.000014.00.00	400.000043.00.00	400.0000xx.00.00	400.000031.00.00

WEMAS traffic cone - load test

WEMAS traffic cone TL-610-41



After the test:
cone and film not damaged.

WEMAS traffic cone Vulkan 1000 mm



traffic cone, two pieces, available as:

- reflective film class RA1 (engineer grade) or film class RA2-B (high intensity)
- partial reflective with film rings class RA1

307.610100.00.01	traffic cone Vulkan 1000 mm with film class RA1 Weight approx. 8,50 kg
307.610752.00.00	traffic cone Vulkan 1000 mm with film class RA2-B Weight approx. 8,50 kg
307.610100.13.02	traffic cone Vulkan 1000 mm with two film rings class RA1 Weight approx. 8,50 kg
packaging unit: 10 pieces	

Traffic cone PVC special colours



traffic cones from PVC one piece
stackable, cone body yellow.

307.610350.04.00	traffic cone with black stripes 320 mm, weight 0,55 kg	(packaging unit 20 pieces)
307.610500.05.00	traffic cone with black stripes 500 mm, weight 1,40 kg	(packaging unit 10 pieces)
307.610500.02.xx	traffic cone special colour 500 mm, weight 1,40 kg	(packaging unit 250 pieces)

WEMAS traffic cone (blown body)



traffic cone as blown body, foot hollow and fillable (water or sand), minimum order
volume per colour approx. 500 cones.

307.610752.00.00	traffic cone body without film rings 750 mm Weight approx. 1,5 kg
307.610752.13.02	traffic cone with reflective film rings 750 mm Weight approx. 1,5 kg
packaging unit: 100 pieces	

traffic cone body four-sided without film rings 750 mm Weight approx. 1,5 kg
traffic cone body four-sided with special markings 750 mm Weight approx. 1,5 kg
packaging unit: 100 pieces

WEMAS traffic cone (reflective) with flash

traffic cone, two pieces pre-assembled with lamp adapter and flash light (like warning lamp 4000) with battery box in the cone body. (Weight cone 750 mm with flash light approx. 9,5 kg).

Standard with film class RA1.

Film class RA1 (engineer grade)

Film class RA2-B (high intensity)

307.610500.00.11	traffic cone with flash 4000 500 mm (double-sided light)
307.610500.00.21	traffic cone with flash 4000 500 mm (single-sided light)
307.610750.00.11	traffic cone with flash 4000 750 mm (double-sided light)
307.610750.00.21	traffic cone with Blitz 4000 750 mm (single-sided light)
307.610750.00.12	traffic cone with Future - flash 750 mm (double-sided light)
307.610750.00.22	traffic cone with Future - flash 750 mm (single-sided light)
307.610100.00.12	traffic cone with Future - flash 1000 mm (double-sided light)
307.610100.00.22	traffic cone with Future - flash 1000 mm (single-sided light)

packaging unit: 1 piece

Surcharge for cone 500 mm film class RA2-B

Surcharge for cone 750 mm film class RA2-B



traffic cone mit Future - flash

traffic cone with flash 4000

WEMAS traffic cone PVC (reflective) with flash

traffic cone, one piece pre-assembled with lamp adapter and flash light (like warning lamp 4000) with battery box in the cone body. (Weight cone 750 mm with flash light approx. 9,5 kg).

Standard with film class RA1.

Film class RA1 (engineer grade)

Film class RA2-B (high intensity)

307.611500.00.11	traffic cone with flash 4000 500 mm (double-sided light)
307.611500.00.21	traffic cone with flash 4000 500 mm (single-sided light)
307.611750.00.11	traffic cone with flash 4000 750 mm (double-sided light)
307.611750.00.21	traffic cone with flash 4000 750 mm (single-sided light)
307.611750.00.12	traffic cone with Future - flash 750 mm (double-sided light)
307.611750.00.22	traffic cone with Future - flash 750 mm (single-sided light)

packaging unit: 1 piece

Surcharge for cone 500 mm film class RA2-B

Surcharge for cone 750 mm film class RA2-B



traffic cone with flash 4000

traffic cone mit Future - flash



BAST tested, according to DIN 67520 part 2, also suitable for Vulkan traffic cones.

307.610002.00.00	Replacement cover for traffic cone 500 mm BAST tested type A (see example)
307.610003.00.00	Replacement cover for traffic cone 750 mm BAST tested type A
900.610005.04.00	Replacement cover for traffic cone 1000 mm BAST tested type A (see example)
packaging unit: 10 pieces	

WEMAS accessories for traffic cones



307.610000.00.00	Lamp adapter for traffic cones (pic. 1) for fixing of WEMAS lamps
390.000102.00.00	information sign, blank for traffic cones (pic. 2) surcharge for name/logo print.
307.610001.00.00	traffic cone-sign holder (pic. 3) for fixing of information signs
packaging unit: 1 piece	

900.610009.00.00	Replacement foot from recycling material for Vulkan traffic cones 500 mm	(packaging unit 10 pieces)
900.610006.00.00	Replacement foot from recycling material for Vulkan traffic cones 750 mm	(packaging unit 10 pieces)

Information board

Information board 1.240 mm high, 730 mm width with flexible foot, absolutely stable and stackable.
 With connecting piece for fixing a Future warning lamp or WEMAS swivel adapter for fixing traffic signs.

302.605501.10.00	Information board with connecting piece and base plate
302.605501.20.00	Information board with swivel adapter (centre piece) and base plate
302.605501.10.11	Information board with film class RA1 Name/logo print on request
302.605501.10.12	Information board with film class RA2-B Name/logo print on request
320.027455.60.00	german sign no. 274-55 - Max. speed 50 km/h, other traffic signs on request
packaging unit: 1 piece	



Delivery without Future warning lamp and traffic sign



base plate



WEMAS driving cone

Driving cone original type „Hahn“, dimension 400 x 425 mm, weight 2,50 kg, height 500 mm

400.460001.00.00	Driving cone 500 mm, fluorescent orange
400.460002.00.00	Ball, yellow, 0,2 kg

packaging unit: 10 pieces



Marking tape



Aluminium marking tape, adhesive, the underground has to be cleaned and dry. Usable for a short time period within the city and on highways. Each role 100 m. Film type FL 310 according to audit report 98 1A 10.04

321.066100.12.00	Marking tape 120 mm yellow thin layer type FL 310
321.066100.12.10	Marking tape 120 mm white thin layer
321.066200.15.00	Marking tape 150 mm yellow thin layer type FL 310
321.066100.00.00	Marking tape 1000 mm yellow thin layer
321.066700.00.00	Marking tape 150 mm black thin layer

BAST tested thick layer marking tapes

321.066300.12.01	Marking tape P6 - A-651 E 120 mm yellow thick layer (BAST 97 1G 03.07)
321.066350.12.01	Marking tape Briteline P5, Typ 1, yellow, 120/150mm x 100m, thick layer (BAST: 99 1G 03.02)
321.066350.12.02	Marking tape Briteline P4, Typ 2, yellow, 120/150mm x 100m, thick layer (BAST: 2002 1VF 08.03)
321.066350.12.03	Marking tape Briteline P5, Typ 2, yellow, 120/150mm x 100m, thick layer (BAST: 2007 1VF 05.06)
321.066351.12.02	Marking tape Briteline P6, Typ 2, yellow, 120/150mm x 100m, thick layer (BAST: 2003 1VF 10.10)

packaging unit: 1 role

For Briteline marking tape please use the primer from Briteline.

Primer



approx. 7 kg primer required for one role (100m).

321.066500.07.00	Primer 7 kg - for marking tape
321.066500.35.00	Primer 35 kg - for marking tape
321.066502.27.00	Primer 25 Liter - for Briteline marking tape

packaging unit: 1 canister

WEMAS accessories for marking tape



1



2

321.066600.00.00	Press role for marking tape 120 mm thin layer (pic. 1)
321.066601.00.00	Laying equipment for marking tape usable for standard widths until max. 30 cm (pic. 2)

packaging unit: 1 role

BAST tested

WEMAS pavement marker

from plastic with reflectors (diameter Ø 120 mm)
BAST identification no.: V 4-30/2000.

390.067002.00.00	Pavement marker yellow R 2 = 2 reflectors
390.067004.00.00	Pavement marker yellow R 4 = 4 reflectors
390.067003.00.02	Pavement marker white R 2 = 2 reflectors
390.067004.00.02	Pavement marker white R 4 = 4 reflectors
390.067002.00.01	Pavement marker orange R 2 = 2 reflectors
390.067004.00.01	Pavement marker orange R 4 = 4 reflectors

packaging unit: 250 pieces



BAST tested

WEMAS warning sign (to glue)

Warning sign to glue.

390.067001.00.00	Warning sign with reflectors
390.067001.00.01	Warning sign top piece
390.067001.00.02	Warning sign base
390.067001.00.03	Warning sign without reflectors at the top piece BAST identification no.: 99 1Z 02.01/Ke

packaging unit: 100 pieces



Traffic cones/markings

WEMAS Warning sign (small)

Warning sign (small) for guide walls with reflective film class RA3

308.090100.00.09	Warning sign (small) yellow for guide walls approx. 50 x 30mm, without film
308.090100.00.19	Warning sign (small) yellow for guide walls approx. 50 x 30mm, with film class RA3

packaging unit: 100 pieces



WEMAS adhesives for fixing pavement marker and warning signs

390.067000.00.00	WEMAS „adhesives for pavement , package each 28 kg
390.067001.00.01	WEMAS two-components adhesives for pavement marker and warning signs - bucket à 10 KG

packaging unit: 1 piece

WEMAS BARRELS

BARRELS FOR A BETTER VISIBILITY

- Shatter-proof and weather resistant
- Long life term due to impact resistant material
- Suitable for standard-pillars DN 60 und DN 78
- According to R-FGÜ 2001

NEW

**WEMAS barrel with
base plate**



Example: cross-walk



Barrel type „R“ DN 160 x 1000 mm

Barrel from blown HDPE, suitable for standard pillars DM 60 and DM 76, with fixing collars and grub screws
Standard without reflective film.
height 1000 mm, delivery with 2 mounting rings.

302.605161.00.00 Barrel type R 160 for tube DN 60 without film

302.605162.00.00 Barrel type R 160 for tube DN 76 without film

packaging unit: 10 pieces

302.605161.00.01 Barrel type R 160 for tube DN 60 with film class RA1

302.605162.00.01 Barrel type R 160 for tube DN 76 with film class RA1

packaging unit: 10 pieces

302.605161.00.02 Barrel type R 160 for tube DN 60 with film class RA2-B

302.605162.00.02 Barrel type R 160 for tube DN 76 with film class RA2-B

390.098000.10.01 Replacement fixing collars and grub screws

390.098000.10.02 Replacement fixing collars and grub screws

packaging unit: 10 pieces



Barrel type „K“ 800 mm

Barrel from blown HDPE stackable, with base plate from recycling material.
Weight approx. 6 kg.

307.630820.02.20 Barrel type K yellow with 2 film rings red

307.630820.00.01 Barrel type K white with film red/white class RA1

307.630820.00.02 Barrel type K white with film red/white class RA2-B

307.630820.01.51 Barrel type K orange with film rings white class RA1

307.630820.02.10 Barrel type K yellow with black film rings (not reflective)

307.630820.50.01 Barrel type K white with film red/white class RA1 and Future warning lamp yellow

packaging unit: 10 pieces



Barrels



stackable



with Future warning lamp

Barrel type „K1“ 1000 mm

NEW



Barrel from blown HDPE stackable, with base plate from recycling material. Available in different colours. Weight approx. 8,5 kg.

Height 1000 mm, diameter lower part 330 mm, top piece 185 mm.

307.630840.00.20 Barrel type K1 red without film

307.630840.00.21 Barrel type K1 red with 2 white reflective film rings class RA1

307.630840.00.10 Barrel type K1 yellow without film

307.630840.00.11 Barrel type K1 yellow with 2 black film rings (not reflective)

packaging unit: 10 pieces



Barrel type „K2“ 1050 mm

Barrel from blown HDPE stackable, with base plate from recycling material. Available in different colours. Weight approx. 7,5 kg, high 1050 mm, diameter lower part 300 mm, top piece 130 mm.

307.630830.00.20	Barrel type K2 red without film
307.630830.00.21	Barrel type K2 red with 2 white reflective film rings class RA1
307.630840.00.50	Barrel type K2 fluorescent orange without film
307.630840.00.51	Barrel type K2 fluorescent orange with 2 white reflective film rings class RA1

packaging unit: 10 pieces



WEMAS "direction sign"



Example „direction sign”
with circle DN 400 mm

“direction sign” from blown HDPE, suitable for standard pillars
DN 60 and DN 76,
standard without reflective film.

302.605191.00.00	Direction sign suitable for circle DN 400 without film
302.605192.00.00	Direction sign suitable for circle DN 600 without film
302.605191.00.01	Direction sign suitable for circle DN 400 film class RA1
302.605192.00.01	Direction sign suitable for circle DN 600 film class RA1
302.605191.00.02	Direction sign suitable for circle DN 400 film class RA2-B
302.605192.00.02	Direction sign suitable for circle DN 600 film class RA2-B
packaging unit: 10 pieces	

WEMAS barrel type „S“ DN 160 x 1000 mm



Example top pieces



Barrel from blown HDPE, to be fixed for example in our base plate with
swivel adapter W 03
standard without reflective film.

302.605170.00.00	Barrel type S DN 160 without eyelet, with ball end without film, with bracket
302.605171.00.00	Barrel type S DN 160 with eyelet and ball end without film, with bracket
302.605180.00.00	Barrel type S DN 160 without eyelet, with cylinder head without film, with bracket
302.605181.00.00	Barrel type S DN 160 with eyelet and cylinder head without film, with bracket
packaging unit: 10 pieces	

Also available with tube 60 mm diameter to encase in concrete.

WEMAS 1/2 barrel type „P“ DN 350 x 750 mm



1/2 Barrel type „P” from blown HDPE, suitable for standard pillars DN 60 and DN 76,
standard without reflective film.

302.605351.00.00	1/2 Barrel type P 350 for pilar DN 60 without film
302.605352.00.00	1/2 Barrel type P 350 for pilar DN 76 without Folie
302.605351.00.01	1/2 Barrel type P 350 for pilar DN 60 with film class RA1
302.605352.00.01	1/2 Barrel type P 350 for pilar DN 76 with film class RA1
302.605351.00.02	1/2 Barrel type P 350 for pilar DN 60 with film class RA2-B
302.605352.00.02	1/2 Barrel type P 350 for pilar DN 76 with film class RA2-B
packaging unit: 1 piece	

WEMAS Barrel DN 200 x 750 mm "balisette"

„Balisette" from blown LDPE, with interior fixing piece, other colours on request available according to DIN EN 13422 (spare parts for fixing not included).

302.605160.07.51	„Balisette" DN 200 with film class RA1	(packaging unit 48 pieces)
302.605160.07.52	„Balisette" DN 200 with film class RA2-B	(packaging unit 48 pieces)
390.098000.10.04	fixation plate for screws M 10 (pic. 2)	(packaging unit 10 pieces)
390.098000.10.10	Balisette incl. fixation adapter (pic. 1)	



fixation with adapter (pic. 1)



fixation plate (for screws) (pic. 2)



Example for use



fixation with M10 screw and dowel



Example for use in production halls

WEMAS accessories for barrels

390.098000.10.01	Fixation ring for barrel Type R with screws for tubes with \varnothing 60 mm (pic. 1)
390.098000.10.02	Fixation ring for barrel Type R with screws for tubes with \varnothing 76 mm (pic. 1)
390.098000.10.11	end cover for barrel Type R for tubes with \varnothing 49 mm (pic. 2)
390.098000.10.12	end cover for barrel Type R for tubes with \varnothing 60 mm (pic. 2)
390.098000.10.05	Distance ring for barrels Type R, S for tubes with \varnothing 60 mm (pic. 3)
390.098000.10.07	Distance ring for barrels Type R, S for tubes with \varnothing 76 mm (pic. 3)

packaging unit: 10 Pieces



pic. 1



pic. 2



pic. 3

Distance ring to use 60 or 76 mm tubes

ACCESSORIES FOR CONSTRUCTION SITES

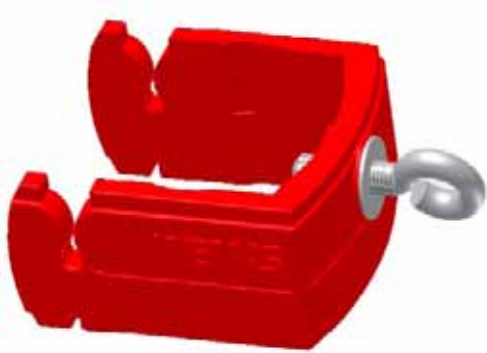

WEMAS U-clamps to install additional signs under standard road signs

registered design



WEMAS climbing aid for Ø60 or Ø76 mm pillars.



Sign clamps

for erecting temporary signs in working environments, all-plastic, shatter proof, available in various colours, 40 x 40 mm / Ø 42.

306.062000.00.00	K0 Sign clamp with eyelets to open
306.063000.00.00	K1 Sign clamp without eyelets
306.063000.00.10	K1-1 sign clamp
306.064000.00.00	K2 Sign clamp with eyelets

packaging unit: box each 100 pieces

K 1



K 0



NEW

K1-1



K 2



U-clamps

The U-clamps are particularly suitable for retroactively erecting signposts and road signs. All-plastic, shatter proof, available in various colours. For pillars until Ø 76 mm.

306.067001.00.00	U1 clamps for shaft tubes 40x40 mm and Ø 42 mm
306.067002.00.00	U2 clamps for shaft tubes until Ø 60 mm
306.067003.00.00	U3 clamps for shaft tubes until Ø 76 mm

packaging unit: box each 100 pieces



U 1 - U 3

registered design



Example for use

WEMAS duplex clamps

Duplex clamps for erecting temporary signs in working environments, all-plastic, shatter-proof, available in different colours.

322.055090.00.00	Duplex clamp for 2 mm flat signs (pic. 1)
322.055090.00.10	Duplex clamp for signs with aluminium edging up to 30 mm (pic. 2)

packaging unit: 40 pieces



Example for use



1



2

WEMAS climbing aid

Climbing aid manufactured in a steel profile construction (foldable) for ensuring the safety replacement of traffic signs on standard posts. Utility model protected - GS tested

322.054060.00.10	Climbing aid for standard tubular Ø60
322.054076.00.10	Climbing aid for standard tubular Ø76

packaging unit: 1 Pieces



Ensures the safe replacement of traffic signs

Shaft tubes

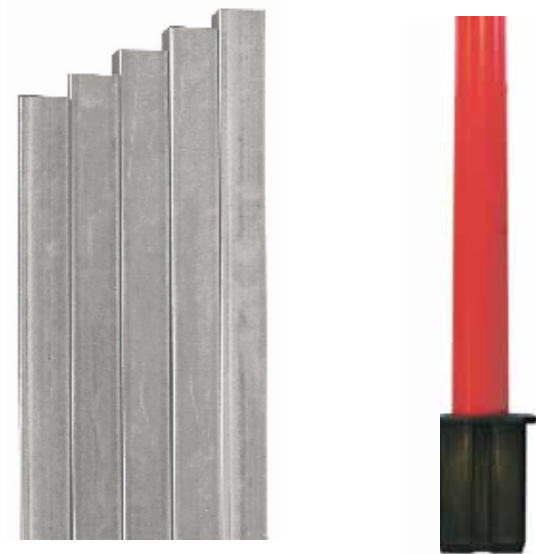

manufactured from galvanised hollow steel profile 40 x 40 x 1,5 mm, anti twist according to TL-Aufstellvorrichtungen.

322.054000.13.00	Length 1300 mm
322.054000.20.00	Length 2000 mm
322.054000.25.00	Length 2500 mm
322.054000.30.00	Length 3000 mm
322.054000.35.00	Length 3500 mm
900.000042.40.40	Cover end for shaft tubes

packaging unit: 100 pieces

390.000553.14.00	plastic tube - red - 1400 x Ø 42mm with casing shoe for holes 60x60mm
390.000553.18.00	plastic tube - red - 1800 x Ø 42mm with casing shoe for holes 60x60mm

packaging unit: 100 pieces

Lock post for temporary signs

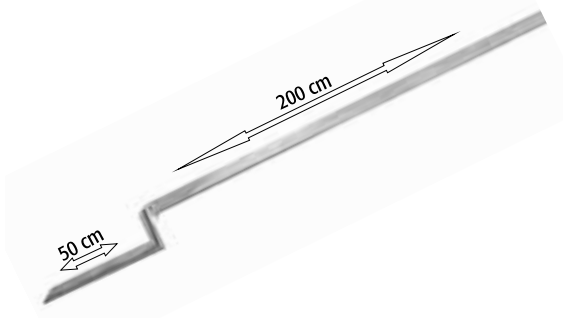

from zinc coated steel, anti twist for erecting temporary signs.

308.059001.00.00	Lock post for temporary signs (2,5 m)
308.059002.00.00	Lock post for temporary signs incl. additional post (3,5 m)
308.059011.00.00	post 1800 mm

packaging unit: 10 pieces

Sign clamps from zinc coated steel



For erecting temporary signs

306.061001.10.00	Sign clamp zinc coated (M10) without eyelets
------------------	---

packaging unit: 100 pieces

Registered design, tested according to "IVZ Norm DIN EN 12899 part 1", standard colour grey, other colours on request available.
Easy installation with only one person.

306.066001.00.00	Pipe clamp R 1 (pic. 1) for tube DN 60 mm, centred hole distance 70 mm
306.066011.00.00	Pipe clamp R 1 for tube DN 76 mm, centred hole distance 70 mm
306.066002.00.00	Pipe clamp R 2 (pic. 2) for tube DN 60 mm, centred hole distance 350 mm
306.066012.00.00	Pipe clamp R 2 for tube DN 76 mm, centred hole distance 350 mm
306.066003.00.00	Pipe clamp R 3 (pic. 3) for tube DN 60 mm, centred hole distance 500 mm
306.066004.00.00	handcuff clamp (pic. 4) for tube DN 60 und DN 76 mm
306.065005.00.00	handcuff clamp long for tube DN 60 und DN 76 mm

packaging unit: 100 pieces



Clamps for altform traffic signs

Registered design, tested according to IVZ Norm DIN EN 12899 Teil 1, standard colour grey, other colours on request available

306.066007.00.00	Clamp for "altform" with max. 30mm boarder traffic signs (pic. 1) for tube 60 mm	(packaging unit 100 pieces)
------------------	--	-----------------------------



Clamps for traffic signs

from zinc coated steel according to DIN EN 12899 part 1
Delivery with 2 screws and nuts.

306.065001.00.00	Clamp R 1-107 zinc coated (pic. 1) for tube 60 mm, centred hole distance 70 mm
306.065002.00.00	Clamp R 2-135 zinc coated (pic. 2) for tube 60 mm, centred hole distance 350 mm

packaging unit: 100 pieces



WEMAS sign stands and erection aids



from galvanised steel suitable from accomodating base plates (28 kg oder 38 kg) and shaft tubes.

308.057005.00.00	TL-sign stand, type F, incl. connection for TL-MB 92 (K1-K6) (pic. 1)
308.057001.00.00	TL-sign stand, incl. connection universal K1 - K6, with additional protection for stacking (pic. 2)
308.057006.00.00	combined erection aid K1-K4 (pic. 3)
308.057009.00.00	combined erection aid K1 until K4 with support 60x60mm (pic. 4)
308.057007.00.40	TL-erection aid type E (K1-K6) with support 40x40 mm only approx. 8 kg. (pic. 5)
308.057007.00.60	TL-erection aid, heavy version, with connection and tube 60x60 mm diameter (foldable). With additional protection for stacking. 2000x650x1000mm (LxBxH), approx. 43 kg. (pic. 6)
packaging unit: 1 Pieces	

Delineator for signs, suitable for shaft tubes 40 x 40 mm. 1000 x 70 mm.

302.605121.70.01	Delineator for shaft tube (without tube, with film class 1 single-sided)
302.605121.70.02	Delineator for shaft tube (without tube, with film class 2 single-sided)
packaging unit: 10 pieces	

5

Group 2
K4 wind force =
Type E + 2 big foot

Group 2 **Groupe 3**
K6 wind force =
Type E + 3 big foot

6

NEW

Erection aid heavy version, stackable for planning table (2 x 1,25 m)

WEMAS sign holder and erection aid

from hot zinc dipped steel, for temporary signs.

308.093040.00.00	guard rail sign holder top piece (pic. 1)
308.039050.00.00	guard rail sign holder end piece (pic. 2)
308.068001.00.00	warning sign holder Height 1200 mm (pic. 3)
308.068002.00.00	warning sign holder big height 1480 mm (like pic. 3)
308.058002.00.00	basement anchor galvanized for tubes 40x40 mm, approx. 8 kg. 2 mm steel (pic.4)
308.058002.00.03	basement anchor galvanized for tubes 40x40 mm, approx. 10 kg. 3 mm steel (pic.4)
308.068002.00.01	basement anchor heavy galvanized for tubes 40x40 and 60x60 mm, approx. 13 kg. (pic. 5)
308.039050.60.40	guard rails sign holder with 40x40 mm and 60x60 mm holes for tubes (pic. 6)

packaging unit: 1 piece

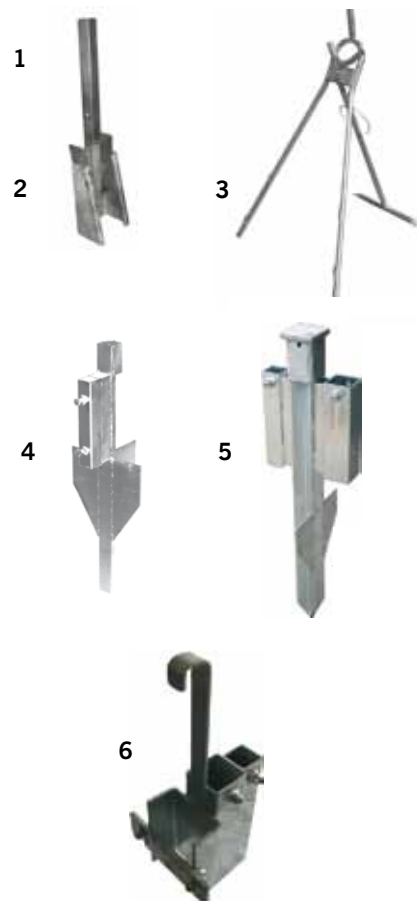

WEMAS accessories for batteries

Accessories for batteries

390.000007.00.00	Battery box with cover and bracket 740x450x270mm (LxWxH)
------------------	---

packaging unit: 1 piece



theft guard for batteries

390.000008.00.10	battery protector - yellow - with elastic strip Also available in green or orange .
------------------	--

packaging unit: 10 piece



Cross for traffic sign

NEW

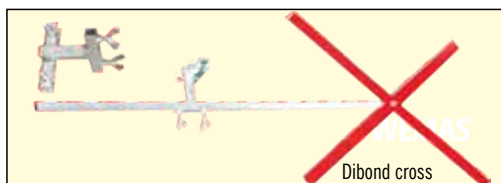

WEMAS cross for traffic signs, twistable, consists of galvanised mounting plate, aluminium cross brace 25x25x1500mm with buffer, Dibond cross 2 x 1200 x 50mm or 2x 1000 x 75mm, film class RA1 red

320.034000.50.02 Cross for traffic signs twistable with Dibond cross 2 x 1200 x 50mm

320.034000.75.02 Cross for traffic signs twistable with Dibond cross 2 x 1000 x 75mm

320.034000.50.01 Cross for traffic signs, fix with Dibond cross 2 x 1200 x 50 mm

320.034000.75.01 Cross for traffic signs, fix with Dibond cross 2 x 1000 x 75mm

packaging unit: 1 piece



Cover tape



Sign cover tape (fluorescent), black-orange-black

320.033050.00.00 Sign cover tape - 50 mm width, 33 m role

packaging unit: 10 pieces

Foot bridges Aluminium

for pedestrian and wheelchairs, antislip and selfcleanig.

309.071000.15.00 Aluminium bridge weight 30 kg
Dimensions: 1700x1000 mm

309.071000.20.00 Aluminium bridge weight 34 kg
Dimensions 2200x1000 mm

packaging unit: 1 piece



Foot bridges wood

for pedestrian and wheelchairs (pic. 1)

309.072000.15.00 Footbridge A weight 64,5 kg
Dimensions 1700x1000 mm according to ZTV-SA

309.072000.20.00 Footbridge A weight 82,0 kg
Dimensions 2200x1000 mm according to ZTV-SA

309.072000.25.00 Footbridge A weight 96,5 kg
Dimensions 2700x1000 mm according to ZTV-SA

packaging unit: 1 piece



pic. 1

for pedestrian not for wheelchairs (pic. 2)

309.073000.15.00 Footbridge B weight 56,5 kg
Dimensions 1500x1000 mm

309.073000.20.00 Footbridge B weight 75,0 kg
Dimensions 2000x1000 mm

309.073000.25.00 Footbridge B weight 86,0 kg
Dimensions 2500x1000 mm

packaging unit: 1 piece



pic. 2

Site fence



recycling base plate

from zinc coated steel, with connecting pieces (steel), base plates from concrete or plastic.

308.088001.35.00	Site fence 3500x2000 mm incl. 1 concrete base plate and connector	(packaging unit 25 pieces)
308.088001.20.00	Site fence door 1100x2000 mm	(packaging unit 1 piece)
308.088002.00.00	Site fence base plate from concrete	(packaging unit 1 piece)
301.001049.00.00	Site fence base plate from recycling material weight 28 kg	(packaging unit 36 pieces)

WEMAS Connector and warning signs for site fences



Connector with warning sign



Standard-connectors



connector as warning sign holder

Standard colour connector grey, other colours on request available

Accessories for site fences

308.088010.00.00	Connector or site fence as holder for warning sign	
308.088010.00.01	Connector or site fence as holder for warning sign with embossing	
308.088020.00.00	Standard connector for site fence	
302.088020.00.01	Standard connector for site fence with embossing	packaging unit: 100 pieces
302.605101.00.01	Clisché for embossing on the connector	
302.605101.00.01	Warning sign for site fence film class RA1 with bracket	
302.605101.00.02	Warning sign for site fence film class RA2-B with bracket	packaging unit: 1 piece

WEMAS Guide post fixture



made from HDPE with two screws. Easy to fix temporarily signs on guide posts. Only for 40x40 oder Ø42 mm tubes.

322.058000.00.00	guide post fixture white	(packaging unit 25 pieces)
------------------	--------------------------	----------------------------

WEMAS Sign post cover

Sign post cover (HD-PE), for standard posts with $\varnothing 60$ mm incl. 2 wedges. Used to install signs in concrete. Length 32 cm.

322.054700.00.60 Sign post cover for posts with $\varnothing 60$ mm incl. 2 wedges

322.054700.00.69 spare part wedges (Set = 2 Pieces)

packaging unit: 10 Pieces



WEMAS Tool for sign post cover

WEMAS fitting tool to fasten and lift the wedges in sign post cover.

322.054700.00.99 Fitting tool

(packaging unit 1 Pieces)

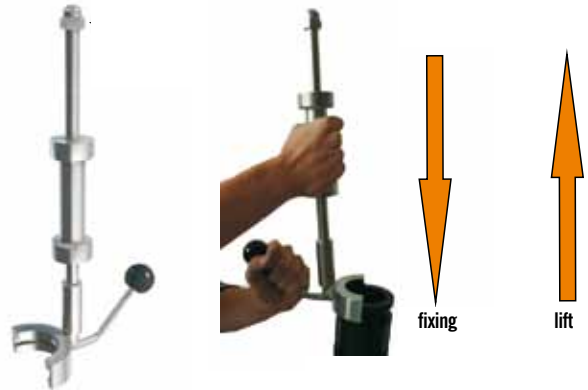

WEMAS Hand barrow wheel - airfree -

WEMAS hand barrow wheel „airfree“ pvc orange or black incl. axle.

390.900000.00.00 hand barrow wheel (screw thread 13,5 mm)

390.900000.00.10 spare part axle (screw thread 11,5 mm)

packaging unit: 10 Pieces



WEMAS warning sign



Warning sign made from HDPE,
without reflective film.

302.607200.00.00	sign 900 mm without film
302.607200.00.00	sign 900 mm with film class RA1
302.607200.00.00	sign 900 mm with film class RA2-B

packaging unit: 10 pieces

WEMAS Curve panel 500x500 mm



Curve panel from blown HDPE, shatterproof, suitable for standard tubes DN 60 and DN 76

302.607000.00.00	Curve panel 500x500 mm mit Absorber for tube DN 60 without film
302.607000.00.01	Curve panel 500x500 mm for tube DN 60 with film class RA1 or RA2-B
302.607100.00.00	Curve panel 500x500 mm mit Absorber for tube DN 76 without film
302.607100.00.01	Curve panel 500x500 mm for tube DN 76 with film class RA1 or RA2-B

packaging unit: 10 pieces

WEMAS Barrier mesh - fence



Barrier mesh - fence (Euromesh)

390.055001.00.00	Orange, length 50 m, height 1,0 m extremely tear resistant, weight approx. 6,5 kg	(packaging unit 1 piece)
308.055002.00.00	Pole for barrier mesh fence	(packaging unit 100 pieces)

WEMAS warning tape pole

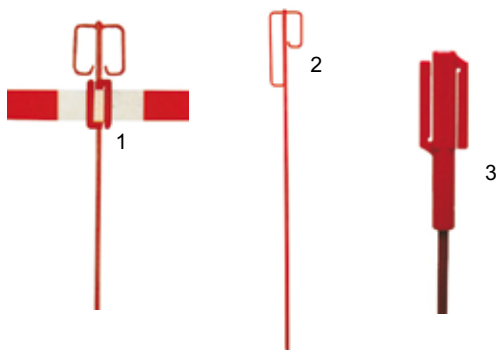

from steel, painted red with spike and safety loop

308.081000.14.00	with spike (pic. 1)
308.082001.14.00	with safety loop (pic. 2)
308.081001.14.00	with plastic spike (3)

packaging unit: 500 pieces

Barrier tape

Colour red/white, extremely tear-resistant.

390.078000.00.00 WEMAS barrier tape red/white 500 m

packaging unit pallet = 250 pieces



Warning tape dispenser Future

Manufactured from PE, with integrated blade, registered design

390.079001.00.00 Dispenser yellow **with** warning tape (500m)

390.079001.00.01 Dispenser red, blue, green, orange, white **with** warning tape (500m)

390.079003.00.00 Dispenser yellow **without** warning tape

390.079003.00.01 Dispenser red, blue, green, orange, white **without** warning tape

packaging unit: 12 pieces



Warning tape dispenser (transparent)

Warning tape dispenser (transparent) with integrated blade:

390.079002.00.00 Warning tape dispenser lightweight
-transparent - **without** warning tape

390.079002.00.001 Warning tape dispenser lightweight
-transparent- **with** warning tape 500 m

packaging unit: 12 pieces



Barrier with chain



barrier from steel, with base plate (round R 450) and chains.

310.083000.42.00	Barrier red/white Ø 42 mm, 1 m high with eyelets and recycling base	
310.083000.60.00	Barrier red/white Ø 60 mm, 1 m high with eyelets and recycling base	
packaging unit: 1 piece		
390.080000.08.00	Plastic chain red/white 8 mm	(packaging unit 25 m)
390.080001.08.00	Plastic chain connector white	(packaging unit 12 pieces)
390.080002.08.00	Plastic chain connector red	(packaging unit 12 pieces)
390.060001.00.00	chasing shoe Universal for base plates 60x60 mm Support Ø42mm pillar (pic. 2)	(packaging unit 12 pieces)

Parking barrier



Parking barrier white ore chrome

(Installing parts not included).

310.087000.00.02	Parking barrier to dowel (hot zinc dipped) hinged with cylinder lock	
310.087000.00.00	Parking barrier to dowel (powder coated) hinged with cylinder lock	
packaging unit: 1 piece		

310.087000.00.04	Parking barrier type A (chrome) hinged with cylinder lock	
310.087000.00.05	Parking barrier type B (chrome) hinged with cylinder lock	
packaging unit: 1 piece		

310.087000.00.01	Parking barrier to set in concrete (incl. key), hinged with cylinder lock (zinc coated o. pic.)	
310.087000.00.06	Parking barrier to set in concrete hinged with cylinder lock (powder coated) and key.	
packaging unit: 1 piece		

Accessories for parking barriers and steel barriers



310.084000.00.00	Key for steel barrier with fire brigade lock	
Replacement cylinder lock for parking barriers and steel barriers		
packaging unit: 1 piece		

Steel barriers Ø 60 mm

from steel, hot zinc dipped and powder coated, available with various fixations.

310.085010.10.00	Steel barrier zinc coated Ø 60 mm without eyelets, 1,35 m high
310.085010.10.02	Steel barrier zinc coated Ø 60 mm with eyelets, 1,35 m high (pic. 1)
310.085020.20.00	Steel barrier red/white Ø 60 mm without eyelets, 1,35 m high
310.085020.20.02	Steel barrier red/white Ø 60 mm with eyelets, 1,35 m high (pic. 2)
310.085040.20.00	Steel barrier red/white Ø 60 mm, 1,3 m high, hinged without eyelets, fire brigade lock
310.085040.20.02	Steel barrier red/white Ø 60 mm, 1,3 m high, hinged with eyelets, fire brigade lock
310.085030.20.00	Steel barrier red/white Ø 60 mm, 1,4 m high, removable without eyelets, fire brigade lock
310.085030.20.02	Steel barrier red/white Ø 60 mm, 1,4 m high, removable with eyelets, fire brigade lock (pic. 3)
packaging unit: 1 piece	

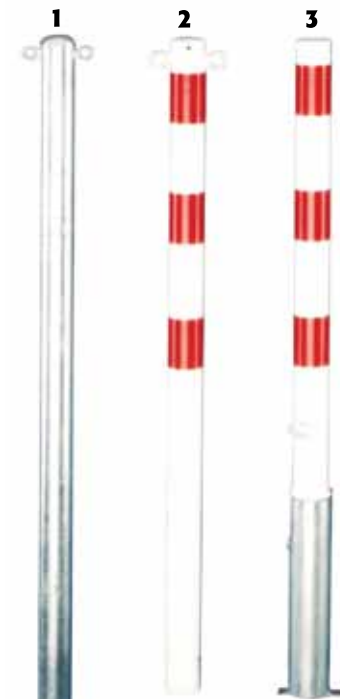

Steel barriers 70 x 70 mm

From steel, hot zinc dipped and powder coated, available with various fixations.

310.084010.10.00	Steel barrier 70x70 mm without eyelets zinc coated, 1,30 m high (pic. 1 but zinc coated)
310.084010.20.02	Steel barrier red/white 70x70 mm without eyelets, 1,30 m high (pic. 1)
310.084010.20.01	Steel barrier red/white 70x70 mm with eyelets, 1,30 m high
310.084020.20.00	Steel barrier red/white 70x70 mm (pic. 2) removable fire brigade lock, 1,30 m high
310.384050.20.00	Steel barrier red/white 70x70 mm removable fire brigade lock, 1,30 m hoch
310.084030.20.00	Steel barrier red/white 70x70 mm (pic. 3) hinged with fire brigade lock
310.084010.20.00	Steel barrier red/white 70x70 mm (pic. 4) hinged with cylinder lock
packaging unit: 1 piece	



Pillar protector



Pillar protector made from HDPE, shatterproof, to save pillars, walls.
Available in two versions and different dimensions.

302.800620.16.01 Pillar protector, yellow Ø 620 mm. for pillars with 160x160, 210x210 und 260x260 mm

302.800820.16.01 Pillar protector, yellow Ø820 mm. for pillars with 160x160, 210x210 und 260x260 mm

packaging unit: 1 piece

WEMAS Big barrel



Big barrel to save factory gates, walls etc.

305.490000.00.50 WEMAS big barrel Ø 500 mm, yellow
height: approx. 1,30 m, base approx. 1,38 m

(packaging unit 1 Pieces)

Wall and rack protector



Wall and rack protector made from HDPE, shatterproof. Available with or without reflective film.

302.800600.02.00 Wall protector 600x250x50 mm (packaging unit 10 pieces)

302.800600.11.00 Corner protector 600x250x150 mm (packaging unit 1 piece)

302.800450.01.00 Rack protector (pic. 3) length 450 mm, for racks with 80, 90 or 100 mm pillars. Fixing with two hook and loop tapes. (packaging unit 10 pieces)



Mortar container

from HDPE, impact resistant with steel frame. Colour yellow,
Tüv GS tested. Dimension: 105x70x46, 200 liter, Weight approx. 20 kg.

390.900200.00.10 mortar container, 200 liter yellow with steel frame

390.900200.00.10 mortar container, 200 liter special colours orange,
green, blue or red with steel frame

390.900200.00 Surcharge for name/logo

packaging unit: pallet = 25 pieces
special colours = 75 pieces



WEMAS rubbish chute

Made from HD-PE incl. TÜV proothen chains and snap hooks

305.490000.00.00 Rubbish chute DN 500 black
incl. chain, length 1.100 mm

305.490001.00.00 Funnel tube for rubbish chute DN 500 black (packaging unit
incl. chain 1 piece)

packaging unit 10 pieces



Industry shovel

390.098001.00.00 Industry shovel

390.098008.00.00 Broom for industry shovel

packaging unit: 1 piece



WEMAS AHK - PE cleaner 99,9%

AHK PE cleaner 99,9%

323.097000.00.00 AHK PE cleaner, 0,7 ltr bottle
with dosing valve

packaging unit: box with 12 bottles



delivery only ex works

WEMAS folding signals



from zinc coated steel with 3 signs, length 900 mm, reflective, other signs available on request

390.076101.00.02 sign No.101 (!) reflective

390.076123.00.02 sign Nr.123 (worker) reflective

packaging unit: 1 piece

390.076000.00.02 Additional sign board for text, not reflective

(packaging unit 1 piece)

WEMAS warning flag



manufactured from polyester,

390.103000.50.50 Warning flag 50x50 cm colour: white orange white

390.103000.75.75 Warning flag 75x75 cm colour: white orange white

packaging unit: 50 pieces

WEMAS Umbrella for welder



Umbrella for welder, diameter 2500 mm

390.092000.00.00 Umbrella for welder heavy

390.092001.00.00 Umbrella for welder light

WEMAS basement charger



Basement charger especially for pipeline construction (Künzelprobe)

390.094000.00.00 Basement charger complete

390.094001.00.00 spare part shaft with winding

WEMAS cap for steel bar



Safety cap for steel bars made from ultra strong plastics

308.082000.00.00 safety cap red (packaging unit 200 Pieces)

308.082000.00.02 holder for cords (packaging unit 500 Pieces)

Example

INDEX

A

Adapter for cone	52
Aluminium trench bridge	67
Anti-theft-device for battery box	65
Assembly aid for ground sleeve	71

B

Barriers	
Base plates	6,13
Battery	39
Battery box	39
Battery tester	39
Blitz barriers	33

C

Cable-bridge	14
Climb aid	63
Collapsible delineator	19
column-guard	76
Cone with flasher	51
Cord nail	78
Cord nail cab	78
Cover tape	68
Cross for traffic signs	68
Curve barriers	29

D

Debris chute	77
Delineator	16,23
Delineator waning lights	36,39

E

Electronics	40
Export barrier	33

F

Fence base plate	12,7
Fence safety clamp	70
Folding traffic signal	78
Future-barrier	24
Future-warning lamp	24

G

Galvanized Barrier (Police/Event Barrier)	30
Ground Sleeve	71

H

Hand lamp	39
-----------	----

I/J

Impact pillar	62
Indicator unit	40
Industry dustpan	77
Information board	53

L

Lens for Warning-lamp	41
Line holder	72

M

Marking tape	54
Mobile Fences	70
Mortar container	77

P

Panel pillar	34
Parking protection guard	74
Pe-cleaner	77
peg	65
Poller	58,59,76
Press on roller	54
Primer	54
Protection Bollards	75
Pvc-tube bridge	14

R

Roadmarking Buttons	55
Reflector	55
Road marking tape	54
Road marking Type	54

Rotating adapter	13,17,23
Rubbish-container	77
Round posts	75

S

Safety bolt	17
Safety delineator	16,23
Safety cab	78
Shaft Tubes	64
Sign clamps	61
Sign clamps	63
Sign for traffic cone	52
Sign holder	67
Sign pillar	66
Speed bumps	15
square jump pillar	75
Storage and transport rack	13,19,23,27,30
Synthetic-catch-fence	72

T

Tape dispenser	73
TL base plate	16,17
TL cone	44,46
TL delineator	16,17
TL road warning lamp	37
TL touch panel	35
TL. Barricade Panel	34,35
Toolkit for warning lamp	41
Traffic cone	42,52
Traffic barrel	56,59
Traffic delineator	16,23
Traffic glows	36,41
Traffic plastic chain	74
Transport rack	13,19,23,27,30
Transport car for baseplates	13
Trench bridge	67
Tube clamping piece	65

U

Universal clamping piece	64
Universal rotating adapter	13,17
Universal tube adapter	13

V

Vario barriers	27
Vario panel fences	27

W

Wall protector	76
Warning flag	78
Warning inductor	66
Warning Lamp	38
Warning lamp 6000	38
Warning Tape	73
Warning tape dispenser	73
warning-seperator	13
Wemas barriers	28,29
Wemas pilot light	37,39
Wheel for handbarrow	71
Wooden trench bridge	67

Allgemeine Verkaufs-, Lieferungs- und Zahlungsbedingungen der Firma Wemas GmbH

1. Gestaltung der Bedingungen

- Die Lieferungen, Leistungen und Angebote der Fa. Wemas GmbH (nachfolgend auch Verkäufer oder bloß wir oder uns genannt) erfolgen ausschließlich aufgrund dieser Geschäftsbedingungen. Diese gelten somit auch für die künftigen Geschäftsbeziehungen, selbst wenn sie nicht nochmals ausdrücklich vereinbart werden. Spätestens mit der Entgegennahme der Ware/Lieferung gelten diese Bedingungen als angenommen. Gegenbestätigungen des Käufers und dem Hinweis auf seine Geschäfts- bzw. Einkaufsbedingungen wird hiermit widersprochen.
- Abweichungen von diesen Geschäftsbedingungen sind nur wirksam, wenn wir sie ausdrücklich schriftlich bestätigen.
- Diese Bedingungen gelten ausschließlich gegenüber Unternehmern, juristischen Personen des öffentlichen Rechts oder öffentlich-rechtlichen Sondervermögen im Sinne des § 310 Abs. 1 BGB.

2. Angebot und Vertragsschluss

- Ist die Bestellung als Angebot gem. § 145 BGB zu qualifizieren, so können wir dieses innerhalb von 4 Wochen annehmen.
- Bei oder nach Vertragsabschluss getroffene Vereinbarungen zwischen unseren Mitarbeitern oder Vertretern und unseren Kunden bedürfen ihrer Gültigkeit unserer Bestätigung; die Vertretungsmacht unserer Mitarbeiter oder Vertreter ist insoweit eingeschränkt.
- Zeichnungen, Abbildungen, Maße, Gewichte oder sonstige Leistungsdaten sind branchenübliche Näherungswerte, so dass handelsübliche Abweichungen zulässig sind. Auch im übrigen bleiben technische Änderungen sowie Änderungen in Form, Farbe, Qualität und/oder Gewicht im Rahmen des Zumutbaren vorbehalten. Das gilt auch, wenn dem Besteller Muster bzw. Proben überlassen wurden. Derartige Angaben sind nicht als Beschaffenheitsgarantien zu verstehen.

3. Liefer- und Leistungszeit, Verzögerung

- Der Beginn der von uns angegebenen Lieferzeit setzt die Abklärung aller technischen Fragen voraus.
- Die von uns genannten Termine und Fristen sind unverbindlich, sofern nicht ausdrücklich etwas anderes vereinbart wurde. Beschaffungsrisiken werden von uns grundsätzlich nicht übernommen.
- Lieferungs- und Leistungsverzögerungen auf Grund höherer Gewalt und aufgrund von Ereignissen, welche der Wemas GmbH die Lieferung wesentlich erschweren oder unmöglich machen (z. B. Streik, Aussperrung etc.), ermächtigen uns, die Lieferungen bzw. Leistungen um die Dauer der Behinderung zzgl. einer angemessenen Anlaufzeit hinauszuschieben. Entsprechendes gilt, wenn die vorstehenden Hindernisse bei unseren Lieferanten oder deren Unterlieferanten eingetreten sind.
- Richtige und rechtzeitige Selbstlieferung bleibt vorbehalten.
- Haben wir eine fällige Leistung nicht vertragsgemäß bewirkt, kann der Käufer vom Vertrag nicht zurücktreten und/oder Schadensersatz statt der ganzen Leistung oder Ersatz vergeblicher Aufwendungen verlangen, soweit die Pflichtverletzung von uns unerheblich ist.
- Die Wemas GmbH gerät nur durch eine Mahnung in Verzug, soweit sich aus dem Gesetz oder dem Vertrag nichts anderes ergibt. Mahnungen und Fristsetzungen des Käufers bedürfen zur Wirksamkeit der Schriftform.
- Die Einhaltung der Lieferverpflichtungen durch uns setzt die rechtzeitige und ordnungsgemäße Erfüllung der Verpflichtungen des Käufers voraus. Die Einrede des nicht erfüllten Vertrages bleibt vorbehalten. Wir sind zur Teillieferung jederzeit berechtigt, soweit dies dem Besteller zumutbar ist.
- Im Falle der Verzögerung der Leistung stehen dem Käufer vorbehaltlich der nachstehenden Regelungen und Voraussetzungen, insbesondere der Haftungsbeschränkung unter Ziffer 3.10., sowie des Vorliegens der gesetzlichen Tatbestandsvoraussetzungen, die gesetzlichen Ansprüche auf Schadensersatz und Rücktritt zu. Voraussetzung ist allerdings, dass der Käufer eine angemessene Frist zur Leistung oder Nacherfüllung bestimmt hat und diese Frist erfolglos abgelaufen ist. Die Bestimmungen der §§ 281 Absatz 2 und 323 Absatz 2 zur Entbehrlichkeit der Fristsetzung bleiben unberührt.
- Der Käufer ist verpflichtet, die Nachfrist gemäß vorstehender Ziff. 3.8 mit der eindeutigen Erklärung zu verbinden, dass er nach dem fruchtlosen Verstreichen der Nachfrist die Lieferung ablehnen und die aus vorstehender Ziff. 3.8 resultierenden Rechte gegenüber uns geltend machen wird. Wurde die Leistung bereits teilweise bewirkt, kann der Käufer Schadensersatz statt der ganzen Leistung nur verlangen, soweit dies sein Interesse an der gesamten Leistung erfordert. Ein Rücktritt vom ganzen Vertrag ist in diesem Fall nur möglich, soweit der Käufer an einer Teilleistung nachweislich kein Interesse hat.
- Bei Verzögerungen der Leistungen haben wir in Fällen des Vorsatzes oder der groben Fahrlässigkeit auch eines Vertreters oder Erfüllungsgehilfen nach den gesetzlichen Vorschriften. Unsere Haftung ist in Fällen grober Fahrlässigkeit jedoch auf den vertragstypischen, vorhersehbaren Schaden begrenzt, wenn keiner der in Satz 5 dieser Bestimmung aufgeführten Ausnahmefälle vorliegt. Im Übrigen wird unsere Haftung wegen Verzögerung der Leistung für den Schadensersatz neben der Leistung auf 5% und für den Schadensersatzanspruch statt der Leistung auf 10% des Wertes der Lieferung/Leistung begrenzt. Weitergehende Ansprüche des Auftraggebers sind – auch nach Ablauf einer uns etwa gesetzten Frist zur Leistung – ausgeschlossen. Die vorstehenden Begrenzungen gelten nicht bei Haftung wegen der Verletzung des Lebens, des Körpers oder der Gesundheit. Eine Änderung der Beweislast zum Nachteil des Käufers ist mit den vorstehenden Regelungen nicht verbunden.
- Vom Vertrag zurückzutreten kann der Käufer nur im Rahmen der gesetzlichen Bestimmungen, wenn wir die Verzögerung der Lieferung zu vertreten haben; eine Änderung der Beweislast zum Nachteil des Käufers ist hiermit nicht verbunden.
- Im Falle des Annahmeverzuges seitens des Käufers bzw. im Falle der Verletzung sonstiger Mitwirkungspflichten des Käufers sind wir berechtigt, die uns zustehenden gesetzlichen Ansprüche geltend zu machen. Die Gefahr des zufälligen Untergangs und/oder einer zufälligen Verschlechterung der Kaufsache geht spätestens zu dem Zeitpunkt auf den Käufer über, in dem dieser in Annahmeverzug gerät.

4. Gefahrenübergang, Verpackung

- Sofern keine abweichende Absprache getroffen wurde, ist Lieferung ab Lager der Wemas GmbH vereinbart. Die Gefahr geht auf den Käufer über, sobald die Sendung an die den Transport ausführende Person übergeben worden ist oder zwecks Versendung unser Lager verlassen hat; dies gilt auch dann, wenn wir den Transport mit eigenen Kräften besorgen.
- Falls der Versand ohne unser Verschulden unmöglich wird, geht die Gefahr mit der Meldung der Versandbereitschaft auf den Käufer über.
- Sofern der Käufer es wünscht, werden wir die Lieferung durch eine Transportversicherung eindecken, die insoweit anfallenden Kosten trägt der Käufer.
- Verpackungen nach Maßgabe der Verpackungsverordnung mit Ausnahme von Transportverpackungen werden nicht zurückgenommen; ausgenommen sind mehrfach verwendbare Transportmittel wie Paletten, Gitterboxen, Collico-Kisten usw. Der Käufer ist verpflichtet, für eine Entsorgung der Einwegverpackung auf eigene Kosten zu sorgen. Die mehrfach verwendbaren Transportmittel werden dem Käufer nur leihweise überlassen; der Käufer ist zur Rückgabe in ordnungsgemäßen Zustand, d. h. restentwert und ohne Beschädigung verpflichtet; bei Verunreinigung oder Beschädigung der Transportmittel trägt der Käufer die Instandsetzungskosten bzw. er muss zum Fremdstaat verpflichtet, soweit eine Instandsetzung unmöglich ist. Die zurückgegebenen Transportverpackungen müssen sauber und frei von Fremdstoffen und nach unterschiedlichen Verpackungen sortiert sein. Andernfalls sind wir berechtigt, vom Abnehmer die bei der Instandsetzung oder Entsorgung entstehenden Mehrkosten zu verlangen.

5. Unmöglichkeit

- Bei Unmöglichkeit der Lieferung/Leistung haften wir in Fällen des Vorsatzes oder der groben Fahrlässigkeit der Wemas GmbH oder eines Vertreters oder Erfüllungsgehilfen nach den gesetzlichen Vorschriften. Unsere Haftung ist in Fällen grober Fahrlässigkeit jedoch auf den vertragstypischen, vorhersehbaren Schaden begrenzt, wenn keiner der in Satz 5 dieser Bestimmung aufgeführten Ausnahmefälle vorliegt. Im Übrigen wird unsere Haftung wegen Unmöglichkeit auf Schadensersatz und auf Ersatz der vergeblichen Aufwendungen auf insgesamt 10% des Wertes der Lieferung/Leistung begrenzt. Weitergehende Ansprüche des Auftraggebers wegen Unmöglichkeit der Lieferung/Leistung sind ausgeschlossen. Diese Beschränkung gilt nicht, soweit in Fällen des Vorsatzes, der groben Fahrlässigkeit oder wegen der Verletzung des Lebens, des Körpers oder der Gesundheit gehaftet wird. Das Recht des Käufers zum Rücktritt vom Vertrag bleibt unberührt.

6. Preise und Zahlungen

- Sämtliche Preise verstehen sich netto ab Lager oder Werk ohne Umsatzsteuer, Verpackung, Versicherung und sonstige Nebenkosten. Sämtliche Nebenkosten (z.B. Fracht, Versicherung, Ausfuhr-, Durchfuhr-, Einfuhr- und andere Bewilligungen sowie Beurkundungen) einschließlich Verpackung gehen zu Lasten des Käufers. Ebenso hat der Käufer alle Arten von Steuern, Abgaben, Gebühren, Zöllen und dergleichen zu tragen, die im Zusammenhang mit dem Vertrag erhoben werden oder sie gegen entsprechenden Nachweis der Wemas GmbH zurückzuerstatten, falls die Wemas GmbH leistungspflichtig geworden ist. Insbesondere hat der Käufer die am Tage der Lieferung geltende Umsatzsteuer zu zahlen.
- Preisänderungen sind zulässig, wenn zwischen Vertragsabschluss und vereinbar-tem Liefertermin mehr als 6 Wochen liegen oder die Lieferung aus Gründen, die der Käufer zu vertreten hat, erst nach Ablauf der 6 Wochen erfolgen kann. Erhöhen sich danach bis zur Fertigstellung der Lieferung die Löhne, die Materialkosten oder die marktmäßigen Einstandspreise, so sind wir berechtigt, den vereinbarten Preis angemessen entsprechend der Kostensteigerung zu erhöhen. Der Käufer steht im Falle der Erhöhung nur dann ein Rücktrittsrecht vom Vertrag zu, wenn die Preiserhöhung den Anstieg der allgemeinen Lebenshaltungskosten zwischen Vertragsabschluss und Auslieferung nicht nur unerheblich übersteigt.
- Der Rechnungsbetrag ist, soweit nicht ausdrücklich etwas anderes vereinbart ist, sofort fällig und wie folgt zahlbar:
 - 8 Tage nach Rechnungsdatum 2 % Skonto
 - 30 Tage nach Rechnungsdatum ohne jeden Abzug
- Kommt der Käufer in Zahlungsverzug, sind wir berechtigt, die sich aus § 288 BGB ergebenden Rechte geltend zu machen.
- Aufrechnungsrechte stehen dem Käufer nur zu, wenn seine Gegenansprüche rechtskräftig festgestellt, unbestritten oder von uns anerkannt sind. Außerdem ist er zur Ausübung eines Zurückbehaltungsrechtes nur insoweit befugt, als sein Gegenanspruch auf dem gleichen Vertragsverhältnis beruht.
- Sind uns Umstände bekannt, welche die Kreditwürdigkeit des Käufers in Frage stellen, sind wir berechtigt, Anzahlungen oder Sicherheitsleistungen unbeschadet weitergehender gesetzlicher Ansprüche zu verlangen.
- Schecks und Wechsel, deren Annahme wir uns vorbehalten, gelten erst nach Einlösung als Zahlung. Etwaige Diskont- und Bankspesen gehen zu Lasten des Käufers.
- Die Ware wird nach Maßgabe dieser Geschäftsbedingungen unter Eigentumsvorbehalt geliefert. Soweit wir mit dem Käufer Bezahlung der Kaufpreisschuld aufgrund des Scheck-/Wechselverfahrens vereinbaren, erstreckt sich der Vorbehalt auch auf die Einlösung des von uns akzeptierten Wechsels durch den Käufer und erlischt nicht durch Gutscrift des erhaltenen Schecks bei uns.
- Gewährleistung**

7.1 Die Gewährleistungsrechte des Käufers setzen voraus, dass dieser seinen nach § 377 HGB geschuldeten Untersuchungs- und Rügeobliegenheiten ordnungsgemäß nachgekommen ist.

7.2 Die gesetzlichen Rückgriffsansprüche des Käufers gegen uns stehen nur insoweit, als der Käufer mit seinem Abnehmer keine über die gesetzlichen Mängelansprüche hinausgehende Vereinbarung getroffen hat.

7.3 Soweit ein uns zu tretender Mangel der Kaufsache vorliegt, ist uns zunächst stets Gelegenheit zur Nacherfüllung innerhalb angemessener Fristen von mindestens 4 Wochen zu gewähren, wobei es dem Käufer vorbehalten bleibt, uns im Einzelfall eine angemessene Frist von weniger als 4 Wochen einzuräumen, sofern eine mindestens 4-wöchige Frist zur Nacherfüllung für ihn nachweisbar unzumutbar ist. Schlägt die Nacherfüllung fehl, stehen dem Käufer vorbehaltlich der nachstehenden Regelungen die gesetzlichen Ansprüche und Rechte zu. Ansprüche des Käufers wegen der zum Zweck der Nacherfüllung erforderlichen Aufwendungen, insbesondere Transport-, Wege-, Arbeits- und Materialkosten, sind jedoch ausgeschlossen, soweit die Aufwendungen sich erhöhen, weil der Gegenstand der Lieferung nachträglich an einen anderen Ort als dem Erfüllungsort verbracht wurde; es sei denn, die Verbringung entspricht seinem bestimmungsgemässen Gebrauch.

7.4 Mängelansprüche bestehen nicht bei nur unerheblicher Abweichung von der vereinbarten Beschaffenheit, bei nur unerheblicher Beeinträchtigung der Brauchbarkeit, bei natürlicher Abnutzung oder bei Schäden, die nach dem Gefahrübergang infolge fehlerhafter oder nachlässiger Behandlung, übermäßiger Beanspruchung, ungeeigneter Betriebsmittel und/oder auf Grund besonderer äußerer Einflüsse entstehen und/oder die nach dem Vertrag nicht vorausgesetzt sind.

7.5 Soweit von uns vorgegebene Betriebs- oder Wartungsanweisungen nicht befolgt, Änderungen nicht zulässiger Art an den Produkten vorgenommen oder Teile ausgetauscht bzw. Verbrauchsmaterialien verwendet werden, und diese Teile und Materialien nicht den Originalspezifikationen entsprechen, entfällt unsere Haftung für infolgedessen aufgetretene Sachmängel, etwas anderes gilt nur, soweit der Gewährleistungsfall nachweislich nicht auf einen der vorgenannten Ausschlussgründe zurückzuführen ist.

7.6 Sachmängelansprüche verjähren in 12 Monaten; die Frist beginnt mit dem Gefahrenübergang. Vorstehende Bestimmungen gelten nicht, soweit das Gesetz gemäß §§ 438 Abs. 1 Nr. 2 (Sachen für Bauwerke), 479 (Rückgriffsanspruch) und 634 a (Baumängel) BGB längere Fristen vorschreibt. Sie gelten ferner nicht im Falle des Vorsatzes, des arglistigen Verschweigens eines Mangels, in Fällen der Verletzung des Lebens, des Körpers oder der Gesundheit oder Freiheit, bei Ansprüchen aus dem Produkthaftungsgesetz, bei einer grob fahrlässigen Pflichtverletzung oder bei der Verletzung wesentlicher Vertragspflichten.

7.7 Unsere Haftung wegen Mängel ist wie folgt begrenzt:

7.7.1 In Fällen des Vorsatzes oder der groben Fahrlässigkeit des Verkäufers oder eines Vertreters oder Erfüllungsgehilfen haften wir nur nach den gesetzlichen Bestimmungen. Im Übrigen haften wir nur nach dem Produkthaftungsgesetz, wegen der Verletzung des Lebens, des Körpers oder der Gesundheit oder wegen der schuldhaften Verletzung wesentlicher Vertragspflichten. Der Schadensersatzanspruch für die Verletzung wesentlicher Vertragspflichten ist jedoch auf den vertragstypischen, vorhersehbaren Schaden begrenzt. Unsere Haftung ist auch in Fällen grober Fahrlässigkeit auf den vertragstypischen, vorhersehbaren Schaden begrenzt, wenn keiner der vorstehend in diesem Absatz aufgeführten Ausnahmefälle vorliegt.

7.7.2 Die Haftung für Schäden durch den Liefergegenstand an Rechtsgehilfen des Käufers, z.B. Schäden an anderen Sachen, ist jedoch ganz ausgeschlossen. Dies gilt nicht, soweit Vorsatz oder grobe Fahrlässigkeit vorliegt oder wegen der Verletzung des Lebens, des Körpers, der Gesundheit gehaftet wird.

7.7.3 Die Regelungen der vorstehenden Ziffern 7.7.1 und 7.7.2 erstrecken sich auf den Schadensersatz neben der Leistung und Schadensersatz statt der Leistung. Sie gelten auch für den Anspruch auf Ersatz vergeblicher Aufwendungen.

7.7.4 Die vorstehenden Haftungsbeschränkungen gelten nicht, wenn der Käufer wegen der Übernahme einer Garantie für das Vorhandensein einer Eigenschaft Schadensersatzansprüche geltend macht, es sei denn, der Zweck der Beschaffenheitsgarantie erstreckt sich lediglich auf die Vertragsmäßigkeit der zu Grunde liegenden Lieferung, nicht aber auf das Risiko von Mangelgeschäden oder sonstiger Vermögensschäden.

7.7.5 Eine Änderung der Beweislast zum Nachteil des Käufers ist mit den vorstehenden Regelungen nicht verbunden.

8. Gesamthaftung

- Eine weitergehende Haftung auf Schadensersatz als in Ziff. 3, 5 und 7 vorgesehen, ist – ohne Rücksicht auf die Rechtsnatur des geltend gemachten Anspruchs – insbesondere wegen Verletzung von Pflichten aus dem Schuldverhältnis und aus unerlaubter Handlung, ausgeschlossen.
- Der Haftungsausschluss gemäß vorstehender Ziff. 8.1 gilt nicht in Fällen des Vorsatzes, der groben Fahrlässigkeit, wegen der Verletzung des Lebens, des Körpers oder Gesundheit, der Haftung nach dem Produkthaftungsgesetz sowie wegen der schuldhaften Verletzung wesentlicher Vertragspflichten. Der Schadensersatzanspruch für die Verletzung wesentlicher Vertragspflichten ist jedoch auf den vertragstypischen, vorhersehbaren Schaden begrenzt. Unsere Haftung ist auch in Fällen der groben Fahrlässigkeit auf den vertragstypischen Schaden begrenzt, wenn keiner der in Satz 1 dieses Absatzes aufgeführten Ausnahmefälle vorliegt.
- Soweit die Haftung von uns ausgeschlossen oder beschränkt ist, gilt dies auch für die persönliche Haftung der Angestellten, Arbeitnehmer, Mitarbeiter, Vertreter und unseren Erfüllungsgehilfen.

9. Eigentumsverhalt

- Die gelieferte Ware bleibt bis zur vollständigen Bezahlung sämtlicher Forderungen aus der Geschäftsverbindung zwischen uns und dem Käufer Eigentum der Wemas GmbH. Die Einstellung einzelner Forderungen in eine lfd. Rechnung sowie die Anerkennung des Saldos berühren den Eigentumsverhalt nicht. Als Bezahlung gilt erst der Eingang des Gegenwerts bei uns.
- Bei verzögerndem Verhalten des Käufers, insbesondere bei Zahlungsverzug, sind wir dazu berechtigt, die Kaufsache zurückzunehmen. In der Zurücknahme der Kaufsache durch uns – auch im Wege der Pfändung – sowie im Herausgabeverlangen liegt ein Rücktritt vom Vertrag.
- In der Pfändung der Kaufsache durch uns liegt stets ein Rücktritt vom Vertrag. Wir sind nach der Rücknahme der Kaufsache zu deren Verwertung befugt. Der Verwertungserlös ist auf die Verbindlichkeit des Käufers abzüglich angemessener Verwertungskosten anzusetzen.
- Der Käufer ist verpflichtet, die Kaufsache pfleglich zu behandeln, diese auf eigene Kosten gegen Feuer, Wasser und Diebstahlschäden ausreichen zum Neuwert zu versichern. Sofern Wartungs- und Inspektionsarbeiten erforderlich sind, muss der Käufer diese auf eigene Kosten rechtzeitig durchführen.
- Bei Pfändung oder sonstigen Eingriffen Dritter sind wir unverzüglich schriftlich zu benachrichtigen, damit wir Klage gem. § 771 ZPO oder ähnlicher ausländischer Rechtsbehelfe erheben können. Soweit der Dritte nicht in der Lage ist, uns die gerichtlichen und außergerichtlichen Kosten einer Klage gemäß § 771 ZPO zu erstatten, haftet der Käufer für den entstandenen Ausfall.
- Der Käufer ist berechtigt, die Vorbehaltsware im ordentlichen Geschäftsgang weiter zu verkaufen; er tritt uns jedoch bereits jetzt alle Forderungen in Höhe des Faktura-Endbetrages (inkl. Mehrwertsteuer) unserer Forderungen ab, die ihm aus der Weiterveräußerung und aus sonstigem Rechtsgrund gegen seine Abnehmer oder Dritte erwachsen, und zwar unabhängig davon, ob die Kaufsache ohne oder nach Verabreichung weiter verkauft worden ist. Wir nehmen die Abtretung an. Ist die abgetretene Forderung gegen den Erwerber der Vorbehaltsware in eine lfd. Rechnung (Kontokorrent) aufgenommen worden, bezieht sich die Abtretung auch auf den anerkannten Saldos unseres Vertragspartners sowie im Falle der Insolvenz des Abnehmers auf den dann vorhandenen „kassalen Saldos“ unseres Vertragspartn-ers. Zur Einziehung dieser Forderung bleibt der Käufer auch nach Abtretung ermächtigt. Die Befugnis der Wemas GmbH, die Forderung selbst einzuziehen, bleibt hiervon unberührt. Wir verpflichten uns jedoch, die Forderung nicht einzuziehen, solange der Käufer seinen Zahlungsverpflichtungen aus den verein-namten Erlösen nachkommt, nicht in Zahlungsverzug ist und insbesondere kein Antrag auf Eröffnung eines Insolvenzverfahrens über sein Vermögen gestellt ist oder Zahlungsverzug vorliegt. Ist aber dies der Fall, können wir verlangen, dass der Käufer uns die abgetretenen Forderungen und deren Schuldner bekannt gibt, die alle zum Einzug erforderlichen Angaben macht, die dazugehörigen Unterlagen aushändigt und den Schuldner (Dritten) die Abtretung mitteilt.
- Die Bearbeitung oder Umwidlung der Vorbehaltsware durch den Käufer wird stets für uns vorgenommen, ohne dass uns daraus Verbindlichkeiten erwachsen. Wird die Vorbehaltsware mit anderen, uns nicht gehörenden Gegenständen verarbeitet, so erwerben wir das Miteigentum an der neuen Sache im Verhältnis des Wertes der Vorbehaltsware (Faktura-Endbetrag incl. MwSt) zu den anderen verarbeiteten Gegenständen z. Zt. der Verarbeitung. Das gilt auch, wenn der Käufer aufgrund der Verarbeitung Alleineigentum erwirbt. Für die durch Verarbeitung entstehende Sache gilt im Übrigen das gleiche wie für die unter Vorbehalt gelieferte Ware.
- Wird die Vorbehaltsware mit anderen, uns nicht gehörenden Gegenständen untrennbar vermischd, so erwerben wir das Miteigentum an der neuen Sache im Verhältnis des Wertes der Vorbehaltsware (Faktura-Endbetrag incl. MwSt.) zu den anderen vermischten Gegenständen zum Zeitpunkt der Vermischung; Erfolg die Vermischung in der Weise, dass die Sache des Käufers als Hauptsache anzusehen ist, so vereinbart, dass der Käufer uns anteilmäßig Miteigentum überträgt. Der Käufer erwartet das so entstandene Alleineigentum oder Miteigentum für uns.
- Wir verpflichten uns, die uns zustehenden Sicherheiten auf Verlangen des Käufers insoweit freizugeben, als der realisierbare Wert von uns zustehenden Sicherheiten die zu sichernden Forderungen um mehr als 10% übersteigt; die Auswahl der freizugebenden Sicherheiten obliegt allerdings uns.

10. Eigentum an Unterlagen, Weitergabe

An von uns erstellten Abbildungen, Zeichnungen, Kalkulationen, Daten und sonstigen Unterlagen behält sich die Wemas GmbH Eigentums- und Urheberrechte vor; sie dürfen Dritten nicht zugänglich gemacht werden. Dies gilt insbesondere für solche Informationen, vor allem schriftliche Unterlagen, die als vertraulich bezeichnet sind; vor ihrer Weitergabe an Dritte bedarf der Käufer unserer ausdrücklichen schriftlichen Zustimmung.

11. Anwendbares Recht, Gerichtsstand, Teilnichtigkeit

- Für alle gegenwärtigen und zukünftigen Ansprüche aus der Geschäftsverbindung mit Unternehmen, juristischen Personen des öffentlichen Rechts sowie öffentlich-rechtlichen Sondervermögen, einschließlich Wechsel- und Scheckforderungen ist ausschließlicher Gerichtsstand der Sitz der Wemas GmbH in Gütersloh. Wir sind jedoch berechtigt, den Käufer auch vor dessen Wohnsitzgerichte zu verklagen.
- Sofern sich aus der Auftragsbestätigung nichts anderes ergibt, ist der Geschäftsitz der Wemas GmbH in Gütersloh Erfüllungsort.
- Für diese Geschäftsbedingungen und gesamten Rechtsbeziehungen zwischen der Wemas GmbH und dem Käufer gilt das Recht der Bundesrepublik Deutschland. Die Anwendung des UN-Kaufrechts (Übereinkommen der Vereinten Nationen vom 11.04.1980 über Vertrag über den Internationalen Warenkauf BGBI 1989 II S 588, b.e.r. 1990 II, 1699) ist ausgeschlossen.
- Sollte sich eine Bestimmung dieser Verkaufs-, Liefer- und Zahlungsbedingungen ganz oder teilweise unwirksam sein oder werden sollte diese eine Regelungslücke enthalten, so wird dadurch die Gültigkeit der übrigen Bestimmungen hiervon nicht

WEMAS SERVICE & SUPPORT

If you have any questions please do not hesitate to contact us.

Your Persons in charge

Ines Heinlein
Sales Assistant

Fon +49 5241 9370 - 36
Fax +49 5241 9370 - 47
E-mail export@wemas.de

Ralf Gerdellebracht
Export Manager

Fon +49 5241 9370 - 32
Fax +49 5241 9370 - 47
E-mail rgd@wemas.de

Edisonstr. 20 • D-33334 Gütersloh
Fon +49 (0) 5241 . 9370-0 • Fax 9370-47

Lise Meitner Str. 1 • D-50259 Pulheim (Brauweiler)
Fon +49 (0) 2234 . 20254- 0 • Fax 20254-20

Lindenthaler Str. 46 • D-04435 Schkeuditz (Radefeld)
Fon +49 (0) 34207 . 72 -713 • Fax 72 -613

export@wemas.de • www.wemas.de

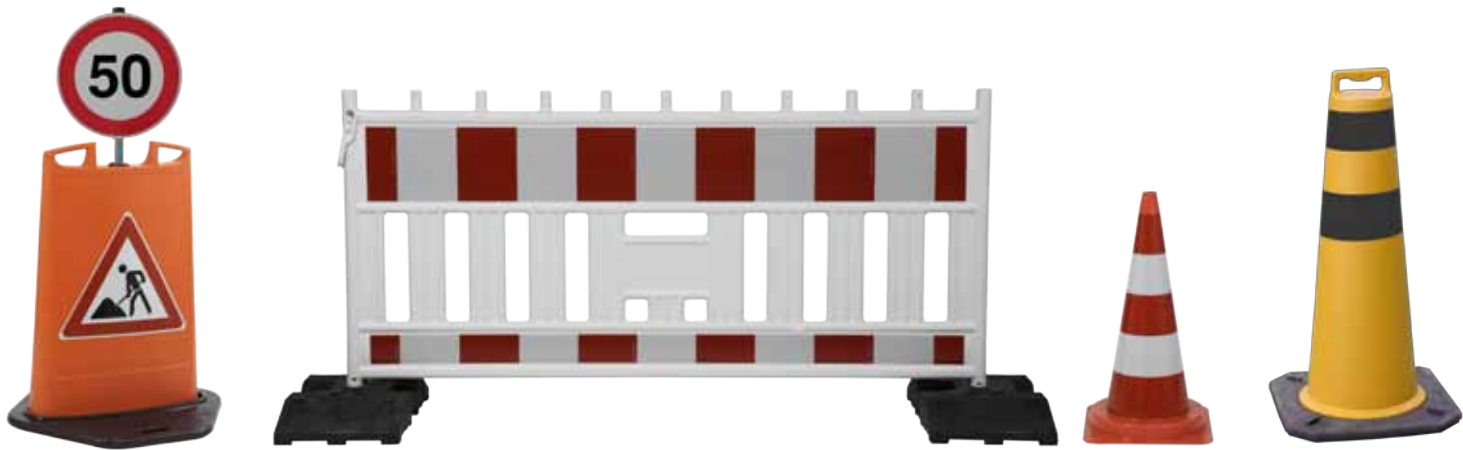

WEMAS – road safety products:
Manufacturing of: Warning lights, delineators, bases, traffic
cones, speed-bumps, safety barrier and other.